

---

## **SERIES 3000 TRACE OXYGEN ANALYZER USER MANUAL**



(shown with optional filter and flow meter)

---

**WARRANTY**

Alpha Omega Instruments Corp. warrants the products delivered to be free from defects in material and workmanship at the time of delivery to the FOB point specified in the purchase order, its liability under this warranty being limited to repairing or replacing, at Alpha Omega Instruments' option, items (excluding the oxygen sensor) which are returned to it **prepaid** within two (2) years from the date of shipment and found to Seller's satisfaction to have been so defective.

Alpha Omega Instrument's one (1) year warranty offers protection for one year from the date of shipment of the Series 3000 Trace Oxygen Analyzer. Any sensor from a Series 3000 Trace Oxygen Analyzer that fails under normal use must be returned to Seller prepaid and, if such sensor is determined by Seller to be defective, Seller shall provide Buyer a replacement sensor. Buyer must provide the serial number of the analyzer from which the sensor has been removed. If a sensor is found to be defective and a new one issued, the warranty of the replacement sensor (s) is for a period of one year from the date of shipment. At times it may be necessary to ship a replacement sensor in advance of receiving one returned for warranty claim. In such cases, if the returned sensor is not covered under warranty, the user will be charged the full price of a replacement sensor. **In no event shall Alpha Omega Instruments Corp. be liable for consequential damages.**

***NO PRODUCT IS WARRANTED AS BEING FIT FOR A PARTICULAR PURPOSE AND THERE IS NO WARRANTY OF MERCHANTABILITY.***

This warranty applies only if:

- (i) the items are used solely under the operating conditions and manner recommended in this manual, specifications, or other literature;
- (ii) the items have not been misused or abused in any manner or repairs attempted thereon;
- (iii) written notice of the failure within the warranty period is forwarded to Alpha Omega Instruments Corp. and the directions received for properly identifying items returned under warranty are followed;
- (iv) the return notice authorizes Alpha Omega Instruments Corp. to examine and disassemble returned products to the extent the Company deems necessary to ascertain the cause of failure.

The warranties stated herein are exclusive. THERE ARE NO OTHER WARRANTIES, EITHER EXPRESSED OR IMPLIED, BEYOND THOSE SET FORTH HEREIN, and Alpha Omega Instruments Corp. does not assume any other obligation or liability in connection with the sale or use of said products.

**Disclaimer of Warranty**

***Alpha Omega Instruments makes no representation or warranties, either expressed or implied, by or with respect to anything in this manual, including, but not limited to, implied warranties of merchantability or fitness for a particular purpose. In no event will Alpha Omega Instruments Corp. be liable for any damages, whether direct or indirect, special, consequential, or incidental arising from the use of this manual. Some states in the USA do not allow the exclusion of incidental or consequential damages. Alpha Omega Instruments Corp. also reserves the right to make any changes to improve the performance of its products at any time and without notice.***

## WARNINGS

### Explanation of graphic symbols



DO NOT TOUCH!



THIS SYMBOL IS INTENDED TO ALERT THE USER TO THE PRESENCE OF IMPORTANT OPERATING AND MAINTENANCE INSTRUCTIONS.

To avoid risk of fire or electrical shock, do not expose the outside surface of the Series 3000 Trace Oxygen Analyzer enclosure to rain or water spray unless the enclosure is rated NEMA 4 (IP66)<sup>1</sup> according to the National Electronics Manufacturers Association. **Never expose the inside of the enclosure to water.**



WHEN POWERED, THE PRESENCE OF UN-INSULATED DANGEROUS VOLTAGES WITHIN THE INSTRUMENT MAY BE OF SUFFICIENT MAGNITUDE TO CONSTITUTE A RISK OF ELECTRICAL SHOCK RESULTING IN INJURY OR DEATH. LEAVE ALL SERVICING TO QUALIFIED PERSONNEL.

**REMOVE ALL POWER SOURCES WHEN INSTALLING OR REMOVING AC POWER OR DATA SIGNAL CONNECTIONS AND WHEN INSTALLING OR REMOVING THE SENSOR, OR ELECTRONICS.**

### RF Disclaimer

This instrument generates and uses small amounts of radio frequency energy, and there is no guarantee that interference will not occur in a particular installation. If this equipment does cause interference to radio or television reception, try to correct the interference by one of more of the following steps:

- 1 Reorient the receiving antenna.
- 2 Relocate the instrument with respect to the receiver.
- 3 Change the AC outlet of the instrument so the instrument and receiver are on different branch circuits.

<sup>1</sup> NEMA stands for the National Electrical Manufacturers Association and the designation IP"XX" signifies European IEC specifications 144 & 529.

<b>TABLE OF CONTENTS</b>		<b>PAGE</b>
	WARRANTY	i
	WARNINGS	ii
SECTION 1.0	INTRODUCTION	1
	General Description	1
	Measurement Ranges	1
	Mechanical Configurations	1
	Optional Equipment	2
	Data Logger	2
	RS-232C Option	2
	RS-485 Option	2
	Sample Filter Option	3
	Filter Element Accessory	3
	Flow Meter Option	3
	Pressure Regulator Option	3
	Sample Pump Option	3
	High Capacity Sample Pump Option	3
	Sensor Heater Option	3
	Battery Operation	3
	General Specifications	4
SECTION 2.0	INSTALLATION PROCEDURES	6
	Unpacking the Instrument	6
	Electrical Installation	6
	Wiring the AC/DC Power	6
	Main Printed Circuit Board (Figure 1)	7
	Oxygen Sensor	8
	Wiring Alarm Relays	8
	Wiring 4-20 mADC and 0-2 VDC Outputs	9

	Wiring to the Optional RS-232C or RS-485 Outputs	10
	Wiring to the Optional Remote Sensor Housing	10
SECTION 3.0	SYSTEM DESCRIPTION	11
	Ambient Temperature Electrochemical Sensor	11
	Alarms	12
	On Board Switch Settings	12
	Fail-Safe Operation	13
	Alarm Settings	13
SECTION 4.0	DETERMINING SYSTEM CONFIGURATION	14
	Model Designation	14
SECTION 5.0	OPERATION	17
	Preparation for Operation	17
	AC Input Voltage Selection	17
	Initial Setup	18
	Mounting Configurations	18
	Panel Mounting	18
	Remote Sensor Mounting	18
	Remote Mounted Sensor Enclosures	19
	Optional Battery Operation (critical information)	19
	Wiring to Remote Sensor Enclosure (Figure 5.0)	20
	Operating Procedures	21
	Power On	21
	Front Panel Controls and Indicators	21
	Setting the Alarms	22
	Alarm Processing	22
	Auto-Clear Operation	22
	Manual Clear Operation	23
	Timing Out	23

---

	Over Range	23
	TTL Signal	23
	Manual Range Changing	24
	Gas Sample Pressure Limits	24
	Sample Connections	24
	Isolation Valves	24
SECTION 6.0	CALIBRATION PROCEDURES	25
	Initial & Routine Calibration Checks	25
	Calibration Gas	25
	Procedure for Checking Calibration	25
	Zero Adjustment	27
SECTION 7.0	REPLACEMENT OF THE OXYGEN SENSOR	28
	Procedure for Replacing the Oxygen Sensor	28
SECTION 8.0	OPTIONAL SERIAL COMMUNICATIONS RS-232C & RS-485	30
	Baud Rates	30
	Standard Commands	30
	RS232/485 Connections	34
SECTION 9.0	RS485 ENHANCED REMOTE CONTROL COMMANDS	35
	General	35
	Special Commands	36
	Added RS485 Enhanced Commands	37
	RS485 Enhanced Commands	39
APPENDIXES	Appendix A Bench Top/Portable Configuration	41
	Part Number BTP	
	Appendix B Panel Mount Configuration	42-45
	Part Numbers PNL, PNR, & PTX	
	Appendix C Remote Sensor Configuration,	46
	Part Numbers BTR & PNR	

	Appendix D	Explosion Proof Electronics/Sensor Configuration Part Numbers EXX	47-49
	Appendix E	Explosion Proof Sensor Configuration Part Number BTX & PTX	50-51
	Appendix F	MSDS for the 3SEN Oxygen Sensor	52-53
ADDENDA	Addendum 1	Sensor Auto-Isolation Feature (P/N 3SOL-Auto)	54
	Addendum 2	AC-Actuated 3-way Solenoid Valve (P/N 3-3waySOL-115) and Sensor AutoPurge Protection (P/N 3-AutoPurge)	56
	Addendum 3	Sample Line Block & Bleed/Sensor-Isolation Sample Gas Delivery System (P/N 3ISO-BB)	58
	Addendum 4	Internal Datalogger (P/N 3DL)	61
	Addendum 5	High Volume Pump (P/N 3PMPH)	63
	Addendum 6	Solenoid Valves, 115 VAC, 50-60Hz (P/N 3-SOL-E)	64

**SECTION 1.0  
INTRODUCTION**

**1.1 General Description**

The Series 3000 Trace Oxygen Analyzer is a microprocessor controlled instrument that can be configured with either one or three trace oxygen ranges. The instrument is powered from either 115/230 VAC, 50-60Hz, or 18-32 VDC input. It also can be battery powered if the Battery Operation Option is purchased. Oxygen values are displayed on a 10.2 mm (0.4") high 4-1/2 digit liquid crystal display (LCD). The oxygen sensor is normally mounted in a sensor housing that contains 1/4" gas inlet and outlet compression fittings. For the bench top/ portable instrument, the sensor housing is located on the rear panel of the electronics enclosure. For instruments equipped with a remote sensor enclosure, the sensor housing is either mounted on the enclosure, as is the case with the watertight NEMA 4X (IP 66) and general purpose NEMA 1 enclosures, or inside the enclosure for the explosion proof, NEMA 7 types.

The front panel of the Series 3000 Trace Oxygen Analyzer contains five switches that provide access to the analyzer's settings. The instrument is equipped with three oxygen alarm relays and one status alarm relay. All four relays are Form C (SPDT) types rated at 10 amps at 115/230 VAC and 30 VDC. The relays are user configurable for fail-safe operation. In addition to the four alarm contacts, the Series 3000 Trace Oxygen Analyzer has a built-in audible alarm and three red LED's for visual indication of an oxygen alarm condition. The audible alarm may be manually canceled at anytime. If the audible alarm is canceled, and the alarm event continues, indications of this condition will still be available through the front panel LED's and relay contact(s).

The Series 3000 Trace Oxygen Analyzer comes equipped with two standard analog outputs, 4-20 mADC and 0-2 VDC. For enhanced communications, the Series 3000 Trace Oxygen Analyzer can also be equipped with optional RS-232C or RS-485 serial communications. Another standard feature of the Series 3000 Trace Oxygen Analyzer is autoranging (three range analyzers only). This feature provides the analyzer with the capability to move either up or down the ranges of measurement automatically.

**1.2 Measurement Ranges with Range Code Designations (codes contained in model number).**

<u>Range Code</u>	<u>Single Ranges</u>	<u>Range Code</u>	<u>Multiple Ranges</u>
Z	0-10,000 ppm	Y	0-100/1,000/10,000 ppm
A	0-5,000 ppm	F	0-50/500/5,000 ppm
B	0-1,000 ppm	G	0-10/100/1,000 ppm
C	0-100 ppm	H	0-5/50/500 ppm
D	0-50 ppm	I	0-1/10/100 ppm

**1.3 Mechanical Configurations**

<u>Mechanical Code</u>	<u>Description</u>
<b>BTP</b>	The analyzer enclosure is suitable for bench top or portable use and comes equipped with a carrying handle. The sensor housing is mounted on the rear of the enclosure (refer to Appendix A). The enclosure is fabricated from polycarbonate with a watertight, NEMA 4X (IP66) rating.
<b>PNL</b>	Similar to the BTP configuration with the addition of an aluminum panel frame. It is not equipped with a carrying handle (refer to Appendix B). The enclosure is made from polycarbonate with a watertight, NEMA 4X (IP66) rating.



<u>Mechanical Code</u>	<u>Description</u>
<b>BTR</b>	This configuration is comprised of two enclosures (electronics and sensor). The electronics enclosure is suitable for bench top installations and is made from polycarbonate with a watertight, NEMA 4X (IP66) rating. The sensor housing is also made from polycarbonate and carries a NEMA 4X (IP66) rating (refer to Appendix C). Three feet of interconnecting cable is standard with additional cabling (up to 4,000 feet)(1,220 meters) available at the time of order.
<b>PNR</b>	Similar to the BTR configuration with the exception of the electronics enclosure that is equipped with a steel panel frame.
<b>BTX</b>	This configuration is comprised of two enclosures (electronics and sensor). The electronics enclosure is suitable for bench top installations and is made from polycarbonate with a watertight, NEMA 4X (IP66) rating. The oxygen sensor housing is mounted inside an aluminum, explosion proof enclosure rated NEMA 7 for use in areas requiring Class 1, Groups B,C,D, Division 3; Class II, Groups E,F,G; and Class III protection (refer to Appendix E). Three feet of interconnecting cable is standard with additional cabling (up to 4,000 feet)(1,220 meters) available at the time of order.
<b>PTX</b>	Similar to the BTX configuration with the exception of the electronics enclosure that is equipped with an aluminum panel frame.
<b>EXX</b>	In this configuration both the electronics and sensor are mounted within a cast aluminum explosion proof enclosure rated NEMA 7 for use in areas requiring Class 1, Groups B,C,D, Division 3; Class II, Groups E,F,G; and Class III protection (refer to Appendix D).

## 1.4 Optional Equipment

The Series 3000 Trace Oxygen Analyzer Monitor incorporates standard features that make it suitable for many applications. However, for certain requirements, the user may desire to augment the capabilities of the instrument by equipping it with one or more options.

### 1.4.1 Data Logger

An optional built-in data logger can be purchased as an option with the Series 3000 Trace Oxygen Analyzer. Please refer to Addendum 4 for further information.

### 1.4.2 RS-232C Option (PN 3RS2)

The RS-232C option is installed at the factory and is designed for applications where enhanced serial communications is required between the Series 3000 Trace Oxygen Analyzer and a host system. The maximum distance between monitor and host is 50 feet (15.2 meters).

### 1.4.3 RS-485 Option (P/N 3RS4)

The RS-485 option is installed at the factory and is designed for applications where enhanced serial communications is required between one or several analyzers and a host system over the same communications channel. The RS-485 format allows both sending and receiving of signals over greater distances than RS-232C, making it ideal for installations where the analyzer(s) are located at distances greater than 50 feet (15.2 meters) from the host. The maximum distance recommended between outermost devices is 4,000 feet(1,220 meters).

**1.4.4 Sample Filter Option (P/N 395S)**

Miniature T-type 316 stainless steel filter with 1/4" compression fittings. Recommended when particle loading exceeds 3 mg/ft<sup>3</sup> and hydrocarbon mist exceeds 0.7 mg/ft<sup>3</sup>. Installed at the factory unless otherwise specified by the customer.

**1.4.5 Filter Element Accessory (P/N 3FBX)**

Filter element for the 395S

**1.4.6 Flowmeter Option (P/N 3FLM)**

Durable one piece clear acrylic flowmeter with easy to read scale in liters per minute.

**1.4.7 Pressure Regulator Option (P/N 3PRR)**

Stainless steel pressure regulator with a 3,000 psig inlet capacity and an adjustable outlet pressure range of 0-5 psig. The regulator does not include a gauge.

**1.4.8 Sample Pump Option (P/N 3PMP)**

Sample pump designed for applications where the sample is under a slight vacuum (12 in. Hg) or at atmospheric pressure. In either case, the sample pressure is insufficient to transport the sample through the sensor housing.

**1.4.9 High Capacity Sample Pump (P/N 3PMPH)**

High capacity pump to be used when the sample is under a vacuum of 5 in Hg (maximum), or at atmospheric pressure. Due to the high capacity of this pump, a valve should be installed on the discharge side of the sensor housing to regulate the flow rate.

**1.4.10 Sensor Heater Option (P/N 3HTR)**

Sensor heater used for applications where low ambient temperatures are encountered, or where constant temperature conditions within the enclosure are desired. This option is available with the explosion proof configurations only and will not work under battery power.

**1.4.11 Battery Operation (P/N 3BAT)**

The Series 3000 can be equipped so that it may be powered from a normal AC/DC source as well as an optional built-in battery pack. The batteries are installed at the factory and are designed for applications where the user desires to power the analyzer for short periods using the batteries. With this option, the Series 3000 will operate for a period of at least 8 hours. If equipped with a sample pump, operating time will be reduced to less than four hours of continuous use. Other items such as alarms, use of the 4-20 mADC output, etc. could reduce the time intervals between battery recharging. The Series 3000 is equipped with a "smart charging" capability for the Nickel Metal Hydride (NiMH) battery pack. Smart charging eliminates the risk of the battery pack being over-charged (not available with explosion proof systems). To achieve a full-charge after the batteries have been discharged, allow for approximately 16 hours of charging time. Please refer to page 19 "Optional Battery Operation" for further details.

**SECTION 1.5**  
**General Specifications<sup>2</sup>**

**PERFORMANCE**

<b>Measurement Ranges</b> (parts per million)	<b>Single-range</b>	<b>Three-range</b>
	0-10,000	0-100/1,000/10,000
	0- 5,000	0- 50/500/5,000
	0-1,000	0-10/100/1,000
	0-100	0- 5/50/500
	0- 50	0-1/10/100
<b>Accuracy<sup>3</sup>:</b>	±1% of full scale (±5% FS 0-1ppm range)	
<b>Linearity:</b>	±1%	
<b>Response Time:</b>	90% of full scale response in less than 10 seconds (typical). The response time for ranges of 0-50 PPM or less depend to a great extent on the design of the sample delivery system including the materials used.	
<b>Sensor Type:</b>	Long-life Ambient Temperature Electrochemical Sensor(Optional CO <sub>2</sub> Resistant Sensor Available).	
<b>Temperature Compensation:</b>	Standard	
<b>Operating Temperature:</b>	(both sensor and electronics): 40° to 104° F (5° to 40° C) <40° F (5° C) use heated sensor enclosure >104° F (40°) cooling of sample gas/sensor required	
<b>Warranty:</b>	2 years electronics, 1 year sensor	

**ELECTRICAL**

<b>Display:</b>	0.4" (10.2 mm) high, 4-1/2 digit LCD
<b>Resolution of Display:</b>	0.1 ppm for ranges <100 ppm 1.0 ppm for ranges >100 ppm
<b>Input Power:</b>	115/230 VAC, 50-60Hz or 18-32 VDC. Optional battery backup available.
<b>Outputs:</b>	4-20 mADC and 0-2 VDC standard as is a TTL output for range identification. RS-232C or RS-485 serial communication optional.
<b>Oxygen Alarm Relays:</b>	Three (3) SPDT Form C contacts rated 10 A @ 30 VDC/115/230 VAC. User selectable for fail-safe or non fail-safe.
<b>Instrument Status Alarm:</b>	Rated identically to the O <sub>2</sub> relays
<b>Audible Alarm:</b>	Internal buzzer with audible cancel
<b>SAMPLE GAS CHARACTERISTICS</b>	1.0 to 2.0 SCFH (0.5 to 1.0 liter/min)

<sup>2</sup> Alpha Omega Instruments reserves the right to change or modify its product specifications without notice.

<sup>3</sup> Stated at constant temperature and constant pressure.

**Flow Rate:**

**Sample Gas Temperature:** 40° to 104° F (5° to 40° C)

**Sample Gas Pressure:** 0.1 to 1.5 psig (0.007 kg/cm<sup>2</sup> to 0.1 kg/cm<sup>2</sup>)

**Entrained Solids:** <3 mg/ft<sup>3</sup>: no in-line filter required  
>3 mg/ft<sup>3</sup>: in-line filter is required

**Hydrocarbon Mist:** <0.7 mg/ft<sup>3</sup>: no in-line filter required  
>0.7 mg/ft<sup>3</sup>: in-line filter is required

**CONSTRUCTION<sup>4</sup>**  
**Electronics Control Unit:** (Bench-top without optional equipment): Polycarbonate with a hinged clear front cover, rated NEMA 4X (IP 66)

**Control Unit Dimensions:** 9.45 in. (240.5 mm) height  
6.50 in. (165.1 mm) width  
6.20 inches (157.5 mm)  
Note: All dimensions are without optional equipment

**Gas Connections:** 1/4" stainless steel compression fittings.

**Sensor Mounting:** Local or optional remote mounting

**Weight:** 11lbs (4.98 kg) (Standard Bench-top Configuration)

---

<sup>4</sup> Other mechanical configurations available-consult the factory.

## SECTION 2.0 INSTALLATION PROCEDURES

### 2.1 Unpacking the Instrument

Upon opening the shipping container, carefully unpack the instrument to check if the outer surfaces have been damaged. If so, report the findings immediately to Alpha Omega Instruments who will provide further instructions.



**NOTE: IF DAMAGE HAS BEEN FOUND, DO NOT PROCEED FURTHER BUT INSTEAD, CONTACT THE FACTORY.**

If there is no apparent damage, check the contents to ensure all items were shipped. In some cases, items may be back-ordered. All damage and shortage claims must be made known to Alpha Omega Instruments within 10 days after receipt of shipment.

There are six screws on the Series 3000 Trace Oxygen Analyzer that fasten the clear cover to the polycarbonate enclosure. Loosen these screws to disengage them from the enclosure, and open the cover exposing the front panel membrane switches. The membrane panel is installed on a metal backing plate that is hinged and swings out in the same direction as the cover. Swing out the membrane panel and check inside the control unit to make sure no components have been loosened or dislodged. If there are loose or dislodged components, notify the factory for further instructions. If all is found to be satisfactory, the installation procedure can begin.

### 2.2 Electrical Installation



**ELECTRICAL INSTALLATION SHOULD BE PERFORMED BY A CERTIFIED ELECTRICIAN AND SHOULD COMPLY WITH APPLICABLE FEDERAL, STATE, OR LOCAL ELECTRICAL SAFETY CODES.**

The Series 3000 Trace Oxygen Analyzer is shipped with a power cord. Some installations may require wiring through conduit into the electrical hub on the rear panel (where the existing power cord is installed). For such installations, removal of the existing power cord can be easily accomplished as described in section 2.2.1. The position of jumper S2, which is located at the lower left quadrant of the printed circuit board determines the line voltage setting. The default setting is 115 VAC, 50-60Hz. If the AC input voltage is changed in the field, please refer to Section 5.1.1 for instructions.

#### 2.2.1 Wiring the AC/DC Power in Place of the Existing Power Cord

Referring to the printed circuit board diagram (FIGURE 1.0) on the next page, locate the AC power terminals 31, 32, and 33. Each connector is equipped with a screw terminal wire holder to facilitate insertion or removal of the wire from the connector. Strip away approximately 0.25 inches (6.0 mm) of insulation from each of the three conductors and then connect AC line, AC neutral, and chassis ground to each connector. Tighten down on each screw turning clockwise to securely fasten each conductor. If the primary power to the instrument is direct current (DC), wire to terminals 29 (BAT+) and 30 (BAT-). Please see cautionary note on page 19 regarding battery operation.

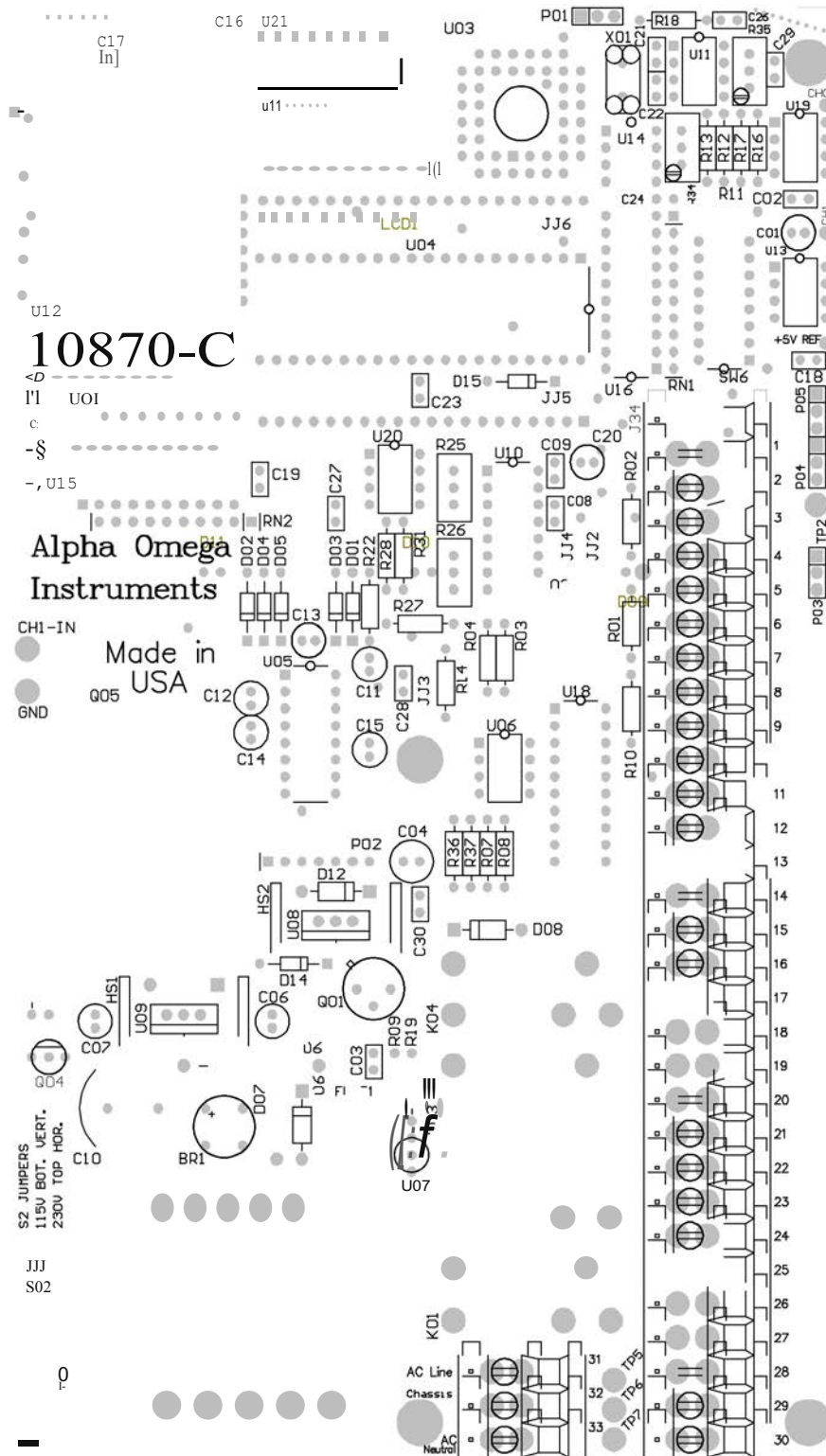

Figure 1

### **2.2.2 Oxygen Sensor**

Wiring of the oxygen sensor has been done at the factory. For information regarding sensor replacement please refer to Section 7.0.

### **2.2.3 Wiring Alarm Relays**

In addition to the cable used for the AC/DC power to the Control Unit, access to the control signals generated from the Series 3000 Trace Oxygen Analyzer is accomplished using signal cabling. This cable is installed through the output cable gland on the rear of the electronics enclosure. The number of conductors needed is determined by the number of functions to be controlled.

The Series 3000 Oxygen Analyzer is equipped with four single pole double throw (SPDT) relays with Form C contacts rated at 10 amperes @ 30 VDC and 115/230 VAC. All alarm relays are user configurable with the three oxygen alarms defaulting to factory setting of **high** oxygen alarms. To configure any of the three oxygen alarm relays to act as low alarms, please refer to Section 5.2.3. As a reminder, Alarm 4 which is not displayed as a discrete alarm on the front panel, is the instrument status alarm.

The technique for wiring to the connectors is identical to that discussed in Section 2.2.1. The wiring configuration is as follows:

#### **Terminal Alarm 1 Relay**

- al**
- 26 Common Contact
- 27 Normally Open Contact
- 28 Normally Closed Contact

#### **Alarm 2 Relay**

- 23 Common Contact
- 24 Normally Open Contact
- 25 Normally Closed Contact

#### **Alarm 3 Relay**

- 20 Common Contact
- 21 Normally Open Contact
- 22 Normally Closed Contact

#### **Instrument Status Alarm**

- 17 Common Contact
- 18 Normally Open Contact
- 19 Normally Closed Contact

TABLE 1.0 on the next page illustrates the various wiring configurations for the four alarms in the Series 3000 Trace Oxygen Analyzer based on whether the alarms are going to be configured for fail-safe or non fail-safe operation.

Contacts shorted for each Alarm Relay	Alarm ON	
	Fail-safe ON	Fail-safe OFF
High or Low O <sub>2</sub> Alarm1 / <b>Relay 1</b>	28(NC) to 26(COM)	27(NO) to 26(COM)
High or Low O <sub>2</sub> Alarm2 / <b>Relay 2</b>	25(NC) to 23(COM)	24(NO) to 23(COM)
High or Low O <sub>2</sub> Alarm3 / <b>Relay 3</b>	22(NC) to 20(COM)	21(NO) to 20(COM)
Low Battery or Instrument Status/ <b>Relay 4</b>	19(NC) to 17(COM)	18(NO) to 17(COM)

TABLE 1.0

Each of the aforementioned alarm relays can be individually configured for fail-safe operation by means of a DIP switch located on the main printed circuit board (refer to Section 3.3). If the instrument is equipped with optional RS-232C or RS-485 communications, the alarms can also be controlled via these outputs. See the caution note below.



**IF THE SERIES 3000 TRACE OXYGEN ANALYZER IS EQUIPPED WITH EITHER RS-232C OR RS-485 COMMUNICATIONS, PLEASE REFER TO SECTION 8.0.**

**2.2.4 Wiring 4-20 mADC and 0-2 VDC Outputs**

The Series 3000 Trace Oxygen Analyzer has two standard linear outputs, 4-20 mADC and 0-2 VDC over the instrument's range(s). These outputs can be measured simultaneously. To wire to the 4-20 mADC output, wire to terminals 12 (4-20) and 13 (AGND). To wire to the 0-2 VDC output, use terminals 8 (positive {labeled DAC}) and 9 (negative {labeled AGND} ). The terminals can be found on the right side of the printed circuit board (refer to FIGURE 1.0) **Note: If a jumper wire is in place between terminals 12 and 13, it must be removed prior to using the 4-20 mADC output.**



**NOTE: IF THE 4-20MA DC OUTPUT IS NOT GOING TO BE USED, IT SHOULD BE SHORTED TO AVOID AN OPEN LOOP WARNING VIA TERMINAL 10 (B-LO)**



**2.2.5 Wiring to the Optional RS-232C or RS-485 Outputs.**

The RS-232C and RS-485 digital communications are options with the Series 3000 Trace Oxygen Analyzer. Unlike the analog outputs, the Series 3000 Trace Oxygen Analyzer can be ordered with either option, but not both. To wire for either the RS-232C or RS-485, use terminals 14 (TXD) for transmit and 15 (RXD) for receive. **Note: You must connect the GND terminal for RS-232C and RS-485 for the instrument to work properly.** Further details on these communication channels are contained in Section 8.0. **Section 8.0 is included as part of this manual even if the Series 3000 Trace Oxygen Analyzer has not been equipped with either of the two aforementioned digital communication loops.**

**2.2.6 Wiring to the Optional Remote Sensor Housing**

Figure 2.0 shows the layout and connections required to wire to the optional remote sensor housing. Please refer to Section 5.1.4 for additional information.

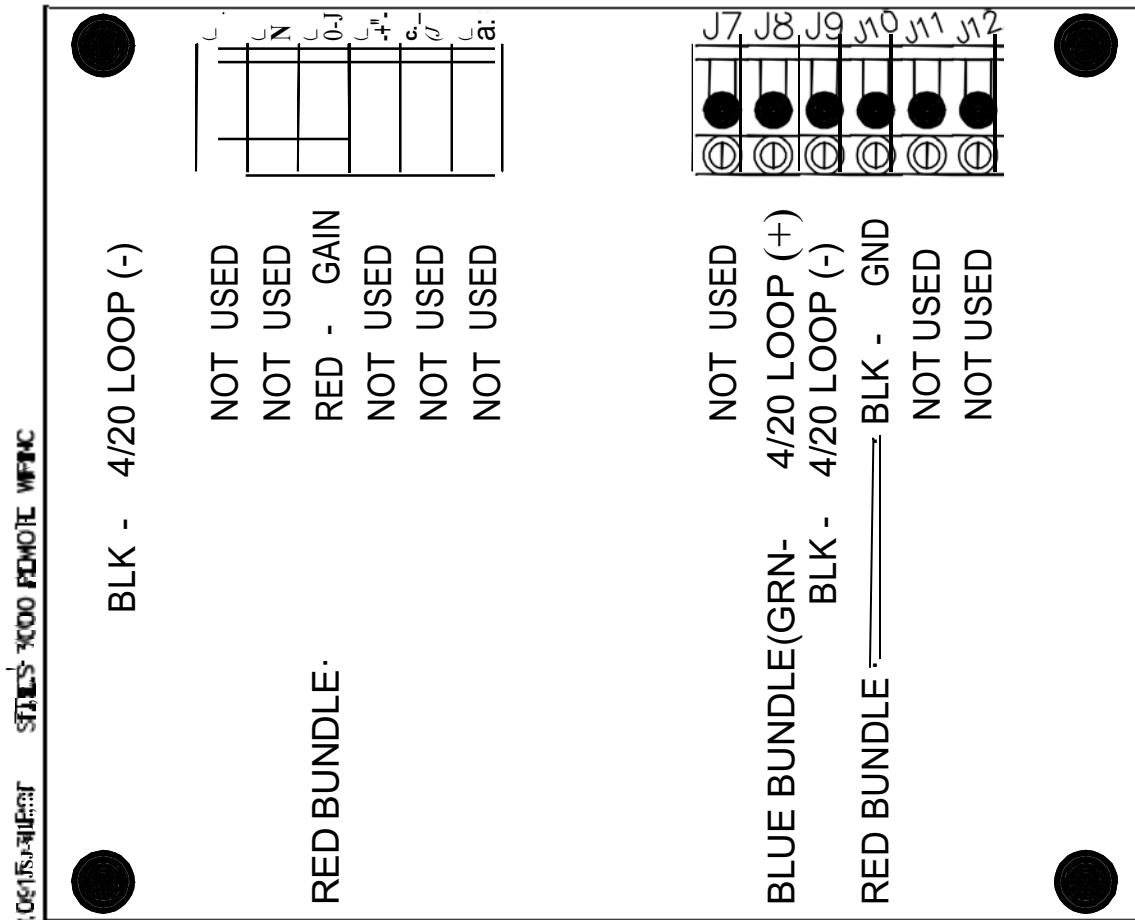

Figure 2.0

SECTION 3.0  
SYSTEM DESCRIPTION

**3.1 Ambient Temperature Electrochemical Sensor**

The Series 3000 Trace Oxygen Analyzer features an advanced trace oxygen sensor. This sensor is a lead-oxygen battery comprised of a lead anode, a gold plated cathode, and an electrolyte consisting of potassium hydroxide. All types of electrochemical transducers have three primary components; a cathode, anode, and electrolyte. In the Alpha Omega Instruments advanced oxygen sensor, the cathode is the sensing electrode or the site where chemical reduction of the oxygen takes place.

The chemical reactions are as follows:

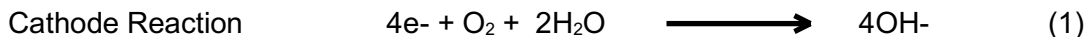

In the above reaction, four electrons combine with one oxygen molecule to produce four hydroxyl ions. This cathodic half-reaction occurs simultaneously with the following anodic half-reaction:



The anode (lead) is oxidized (in a basic media) to lead oxide and in the process, two electrons are transferred for each atom of lead that is oxidized. The sum of the half-reactions (1) and (2) results in the overall reaction (3):



From this reaction it can be seen that the sensor is very specific for oxygen providing there are no gaseous components in the sample stream capable of oxidizing lead. The only likely compounds that meet this requirement are the halogens (iodine, bromine, chlorine, and fluorine).

In reaction (1), four electrons are transferred for each oxygen molecule undergoing reaction. In order to be reacted, an oxygen molecule must diffuse through both the sensing membrane and the thin film of electrolyte maintained between the sensing membrane and the upper surface of the cathode. The rate at which oxygen molecules reach the surface of the cathode determines the electrical output. This rate is directly proportional to the concentration of oxygen in the gaseous mixture surrounding the sensor cell.

### **3.2 Alarms**

One of the primary functions of the instrument is to alert the user when alarm conditions have occurred. To this end, four alarm relays, each capable of switching up to 10 Amperes, are provided. These isolated relays are single pole double throw (SPDT) relays for maximum user flexibility. These relay outputs, along with the simultaneous LED and annunciator operation, serve to give maximum notification to the user of an alarm condition.

An "open collector" output, more appropriately called an "open drain output", provides an additional level of operator output for signaling alarm purposes. This "open drain output" from a 50 volt MOSFET transistor, is normally open, but will close or short to ground to indicate an alarm condition if the 4 to 20 milliamp loop is open.

The front panel display and Relay #4 will indicate a low battery if the instrument is equipped with the Battery option.

### **3.3 On Board Switch Settings**

Setting the alarms for fail-safe operation and automatic alarm clearing can be accomplished by using an on board switch bank (SW6) located in the upper right quadrant of the printed circuit board (refer to FIGURE 4.0). This switch bank has eight (8) individual switches for configuring the Series 3000.

The Series 3000 Trace Oxygen Analyzer is shipped from the factory with switch #8 in the "ON" position "user configuration" mode. In this setting, the analyzer will be configured using battery backed configuration information. This is the default setting. This means the analyzer will ignore the switch settings altogether and "boot" up to user configured memory. If switch #8 is in the "OFF" position "switch settings" mode, the analyzer will read the other switches in order to configure the analyzer when power is applied or, a warm boot has occurred. The user configured memory is that which is set up via the front panel or external communications loop (refer to Section 5.2.).

**3.3.1 Fail-Safe Operation**

The Series 3000 Trace Oxygen Analyzer will "boot" up based on the settings of oxygen alarm switches #1 through #4. Switches #1 through #4 control the fail-safe operation for each of the four alarm relays. Each switch must be turned "ON" to be fail-safe (refer to FIGURE 4.0). In the fail-safe mode, upon an alarm condition, the corresponding relay will change state (either open or closed) upon loss of AC power. The factory settings for switches #1 through #4 is "OFF" (normal operation or non fail-safe).

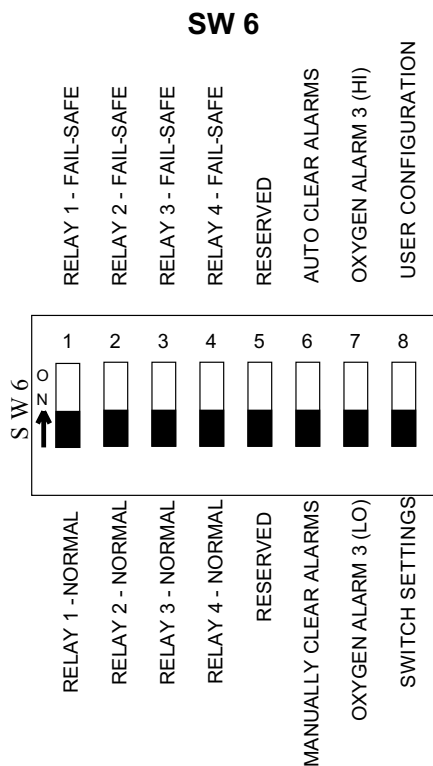

**FIGURE 4.0**

**3.3.2 Alarm Settings**

With switch #8 in the "OFF" position, the Series 3000 Trace Oxygen Analyzer defaults to configuring Oxygen Alarms 1 & 2 as high alarms. Alarm 3 will be configured based on the setting for switch 7. With switch #8 in the "ON" position, all user settings will be retained. Note: to read the switches while operating, just perform a "warm boot" with SW6, switch #8 in the OFF position. (See Section 5.2.1 )



**IF ANY ALARM IS NOT GOING TO BE USED, IT SHOULD BE DISABLED. TO DO SO, FIRST CONFIGURE EACH ALARM AS A LOW ALARM, AND THEN SET THE ALARM TO 0.00**

**SECTION 4.0  
DETERMINING SYSTEM CONFIGURATION**

**4.1 Model Designation**

Before proceeding to the following sections, it is important to determine the system configuration for the selected analyzer. To best accomplish this, refer to the purchase order to obtain the part number that

was ordered and compare it to the range, input power configuration, and mechanical configuration shown below.

**P/N KEY:**

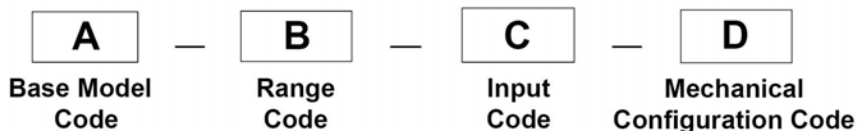

	Code	Base Model
<b>A</b>	<b>3000</b>	Series 3000 Trace Oxygen Analyzer with three alarm relays, instrument status alarm relay, digital display, audible alarm, visual alarm indicators, NEMA 1 enclosure, 4-20 mADC and 0-2 VDC analog outputs, and manual sensor isolation valves.

Oxygen Ranges	
Range Code	Range (ppm)
Z	0-10,000
A	0-5,000
B	0-1,000
C	0-100
D	0-50
Y	0-100/1,000/10,000
F	0-50/500/5,000
G	0-10/100/1,000
H	0-5/50/500
I	0-1/10/100

Input Power Configurations	
Code	Input Power
<b>115</b>	115 VAC 50-60 Hz
<b>230</b>	230 VAC 50 Hz

<b>Mechanical Configurations</b>	
<b>Code</b>	<b>Configuration</b>
<b>BTP</b>	Benchtop/portable electronics enclosure with carrying handle. The sensor is mounted on the rear of the electronics enclosure.
<b>PNL</b>	Panel mounted electronics enclosure with the sensor mounted on the rear of the electronics enclosure.
<b>BTR</b>	Benchtop electronics enclosure without carrying handle. The sensor is mounted within a separate NEMA 4X (IP 66) enclosure. Three feet (1 meter) of interconnecting cable is provided to connect the electronics to the sensor. Additional cabling, up to a maximum of 4,000 feet (1,220 meters), is available.
<b>PNR</b>	Panel mounted electronics enclosure. The sensor is mounted within a separate NEMA 4X (IP 66) enclosure. Three feet (1 meter) of interconnecting cable is provided to connect the electronics to the sensor. Additional cabling, up to a maximum of 4,000 feet (1,220 meters), is available as an option.
<b>BTX</b>	Benchtop electronics without carrying handle. The sensor is mounted within a separate explosion proof enclosure rated NEMA 7 for use in areas requiring Class 1, Groups B,C,D, Division 1; Class II, Groups E,F,G; and Class III protection. No interconnecting cabling is provided. Cable is available up to a maximum of 4,000 feet (1,220 meters) as an option.
<b>PTX</b>	Panel mounted electronics. The sensor is mounted within a separate explosion proof enclosure rated NEMA 7 for use in areas requiring Class 1, Groups B,C,D, Division 1; Class II, Groups E,F,G; and Class III protection. No interconnecting cabling is provided. Cable is available up to a maximum of 4,000 feet (1,220 meters) as an option.
<b>EXX</b>	Electronics and sensor housing are mounted within one explosion proof enclosure rated NEMA 7 for use in areas requiring Class 1, Groups B,C,D, Division 1; Class II, Groups E,F,G; and Class III protection.

Configuration example : Series 3000 Trace O<sub>2</sub> Analyzer with a range of 0-100/1,000/10,000 PPM, a selected power input of 115 VAC 50-60 Hz, with a benchtop/portable mechanical configuration (p/n 3000-Y-115-BTP)

OPTIONS/ACCESSORIES

Item Description	P/N
<b>RS-232C Serial Communications</b> -Maximum distance between host and analyzer is 50 feet (15 meters).	3RS2
<b>RS-485 Serial Communications</b> -Provides capability to communicate with several analyzers up to a maximum distance of 4,000 feet (1,220 meters).	3RS4
<b>High Capacity Sample Filter</b> -316 stainless steel (SS) body with 316 SS filter element. Filters particle sizes > 5 microns. The filter housing is equipped with 1/4" compression fittings.	395S
<b>Coalescing Filter</b> -Filter with aluminum housing. Recommended with samples containing a very light mist and particles > 30 microns.	3CF
<b>Spare Filter Elements</b> for the 3CF	3CFE
<b>Spare Filter Elements</b> - 316 stainless steel filter elements for the 395S Filter.	3FBX
<b>Flowmeter</b> -Durable one-piece acrylic flowmeter (without flow control adjustment).	3FLM
<b>Flowmeter</b> - Durable one-piece acrylic flowmeter (with flow control adjustment).	3FLMC
<b>Pressure Regulator</b> - Aluminum body with a maximum pressure input of 100 psig (7.03kg/cm <sup>2</sup> ).	3LPR
<b>Pressure Regulator</b> -Stainless steel pressure regulator with a 3,000 psig (211 kg/cm <sup>2</sup> ) inlet capacity and an adjustable outlet pressure range of 0 to 5 psig (0 to 0.35 kg/cm <sup>2</sup> ) (does not include indicating gauge).	3PRR
<b>Sample Pump</b> -For applications when the sample pressure is from 12 psia (827 mbar) to 14.9 psia (1027 mbar). Maximum sample line limit is 25 feet (7.6 meters). When mounted to rear of instrument, the overall rating for the analyzer enclosure is general purpose, NEMA 1.	3PMP
<b>High Capacity Sample Pump</b> - For applications when the sample pressure is from 10 psia (690 mbar) to 14.9 psia (1027 mbar) or, if the sample line exceeds 25 feet (7.6 meters). Should be used with the 3FLM flowmeter.	3PMPH
<b>Sensor Heater</b> -Available with BTX, PTX, and EXX only. Designed to keep the sensor from being damaged due to low temperatures.	3HTR
<b>Mounting Plate</b> - Painted aluminum mounting plate (16" x16") (40 cm x 40 cm nominally) used for mounting items such as the remote sensor enclosure, flowmeter, sample pump, etc. Items mounted at factory.	3MPL
<b>Replacement Sensor</b> - Replacement sensor for the Series 3000 Trace Oxygen Analyzer. <i>Note: When a replacement or spare sensor is ordered, the measuring range(s) of the instrument must be included.</i>	3SEN
<b>Solenoid Valves</b> - Pair of AC valves that together with a PLC or other control device can be programmed to automatically isolate the oxygen sensor when not in use.	3IOV
<b>Internally Mounted Data Logger</b> : Capable of storing up to 32,000 oxygen readings	3DL
<b>Battery Operation</b> : Nickel Metal Hydride Battery Pack used to power instrument when AC power is not available. The instrument is equipped with a built-in battery charger.	3BAT
<b>CO<sub>2</sub> Resistant Trace Oxygen Sensor</b> - For the Series 3000 Trace Oxygen Analyzer.	3SEN CO <sub>2</sub>
<b>Block &amp; Bleed Sample / Sensor- Isolation Gas Delivery System</b> - Convenient means to purge (bleed) the sample line before switching to sample, producing ultra fast response and improved protection from upsets. Recommended for "portable" or "transportable" trace O <sub>2</sub> analysis applications (spot or intermittent trace O <sub>2</sub> readings at different sample tap locations).	3ISO-BB

Section 5.0  
OPERATION

5.1 Preparation for Operation

5.1.1 AC Input Voltage Selection

At the time of shipment, the Series 3000 Trace Oxygen Analyzer is set up to operate on the line voltage specified in the purchase order ( if the Series 3000 has been equipped for battery operation, refer to page 19 for important instructions). If the line voltage is not specified, the instrument will be configured for operation on 115 VAC, 50-60Hz. If the instrument is going to be powered from an external DC power source, move on to the next section.

The input voltage can be changed in the field by changing jumper (S2) located on the lower left quadrant of the printed circuit board (refer to FIGURE 1.0) When the Series 3000 is configured for operation on 115 VAC, it contains a 0.5 ampere slow blow fuse (fuse type is Wickman 374050004). For 230 VAC operation, the same value fuse can be used. However, please refer to item 3 below for the jumper change required to change AC voltage inputs.



**BE SURE TO USE THE APPROPRIATE FUSE RATING IF THE INSTRUMENT IS CHANGED TO A DIFFERENT AC LINE VOLTAGE .**

Changing the AC input can be done as follows:

1. Disconnect the Series 3000 Trace Oxygen Analyzer from all AC power.
2. Swing out the front panel to gain access to the main printed circuit board (refer to Section 2.1 for instructions). **For explosion proof instruments, removal of the cover bolts must be done to gain access to the inside of the instrument.**
3. Examine the jumpers on the main circuit board. Shown below are the two ways of installing the AC input selection jumpers at S2.

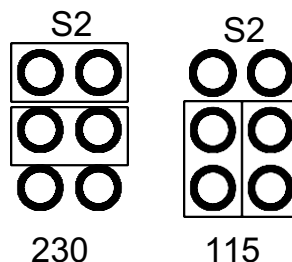

4. To change the AC configuration, remove the jumpers and place them according to the above diagram.
5. Remove the fuse located on the main printed circuit board (refer to FIGURE 1.0) and replace it with one of the proper value for the AC input voltage selected.
6. Reassemble the instrument and proceed to the next section.



### 5.1.2 Initial Setup



IN GENERAL, IT IS VERY IMPORTANT THAT ELECTROCHEMICAL OXYGEN SENSORS BE KEPT SHORTED WHEN POWER IS OFF. THE PURPOSE OF SHORTING THE SENSOR IS TO PROVIDE A LOW RESISTANCE CURRENT PATH THAT FACILITATES THE ELECTROCHEMICAL CONVERSION OF OXYGEN DESCRIBED IN SECTION 3.1. WITHOUT SHORTING THE SENSOR, EXCESS OXYGEN BUILDS UP ON THE CATHODE SURFACE, AS WELL AS IN THE ELECTROLYTE, PROLONGING CONSIDERABLY THE TIME IT TAKES FOR THE INSTRUMENT TO PROVIDE ACTUAL OXYGEN MEASUREMENTS. IF THE OXYGEN SENSOR IS EXPOSED TO EVEN SMALL CONCENTRATIONS OF OXYGEN WITHOUT BEING SHORTED, RESUMPTION OF NORMAL OPERATION WILL BE SIGNIFICANTLY PROLONGED. AS A RESULT, INCORPORATED INTO EACH SERIES 3000 TRACE OXYGEN ANALYZER ARE PROVISIONS TO AUTOMATICALLY KEEP THE SENSOR SHORTED WHEN THE INSTRUMENT IS NOT UNDER POWER.

The Series 3000 Trace Oxygen Analyzer is essentially ready to use out of the shipping container. The analyzer has been calibrated at the factory and, under normal conditions, recalibration should not be required at initial start-up. However, due to the rigors of shipment, it is possible that settings within the instrument could change and, as a result, it is highly recommended that the calibration be checked prior to initial startup. **Isolation valves have been installed on the input and output of the sensor housing to keep the sensor inerted during shipping. Do not open these valves until ready to process the sample gas through the sensor housing. When the instrument is not in use, keep the sensor housing inerted.**



THOUGH IT IS NOT A NECESSITY, IT IS HIGHLY RECOMMENDED THAT THE CALIBRATION OF THE ANALYZER BE CHECKED PRIOR TO INITIAL STARTUP. THE ANALYZER HAS BEEN FULLY CALIBRATED AT THE FACTORY.

### 5.1.3 Mounting Configurations

**Bench top/Portable (BTP Configuration)** The BTP is the basic Series 3000 Trace Oxygen Analyzer configuration that has the sensor housing mounted on the rear panel of the electronics enclosure. The analyzer is designed for either bench top or portable applications. All gas and electrical connections are located on the instrument's rear panel for ease of access.

**Panel Mounting (PNL)**- Like its BTP counterpart, the sensor housing is mounted on the rear panel of the electronics enclosure. In the PNL configuration, a panel mounting frame is supplied. The panel cutout dimensions are provided in Appendix B. Make the appropriate panel modifications as indicated in the drawing.

**Remote Sensor Mounting**- There are several remote sensor mounting configurations for Series 3000 Trace Oxygen Analyzer. Check the purchase order to determine what mechanical configuration designator was used to designate the configuration. The various mechanical configurations are described in Section 4.1 and are shown in the Appendices.

#### 5.1.4 Remote Mounted Sensor Enclosures

For analyzers equipped with remote mounted sensor enclosures, the electronics control unit and remote mounted sensor enclosure need to be connected via interconnecting cable. If a standard length of cable is ordered with the instrument (3 feet) (1 meter), wiring to the electronics control unit has been done at the factory. For all nonstandard lengths, the cabling will be shipped without being terminated. Please refer to Figure 1.0 to locate the various terminals for connecting the sensor, alarms, outputs, pump, heater, etc. Figure 5.0 shows the terminal connections for the remote sensor enclosure. Please refer to this diagram when attempting to interconnect the electronic control unit with the remote sensor enclosure.

#### Optional Battery Operation



#### NOTE FOR BATTERY OPERATION

If the Series 3000 has been equipped with optional NiMH batteries, it will provide up to 3-4 hours of continuous operation on a fully charged set of batteries (without an on-board sample pump). If the Series 3000 is equipped with an optional on-board sample pump, the expected time between recharges will be approximately 2 hours of continuous operation.

The batteries should be fully charged when the analyzer is received by plugging the analyzer into an AC outlet with the power switch in the ON position. Allow at least 16 hours of recharging time. **NOTE: THE POWER ON SWITCH MUST BE KEPT IN THE "ON" POSITION DURING CHARGING.**

The battery option should never be used when the analyzer is powered from a separate DC source. This will cause the batteries to overcharge which may cause the batteries to explode. Be certain all wiring (alarms, remote sensor, RS-232C, etc.) has been done before applying AC power to the instrument.

#### CRITICAL INFORMATION

When operating the Series 3000 Trace Oxygen Analyzer on battery power, if the message "LO-BAT" is displayed on the front panel LCD, this indicates that battery power has been depleted and the batteries need to be recharged. When "LO-BAT" is displayed, the user should immediately power the analyzer from an AC power source (to recharge the batteries) or place the power switch in the "OFF" position to allow recharging at a later time. Recharging time is approximately 16 hours.

If the "LO-BAT" warning is ignored, within a short period of time the LCD will display the message "HALT". If the Series 3000 Trace Oxygen Analyzer is kept operating on battery power when the "HALT" message is displayed, there is a risk that the batteries may be permanently damaged. To avoid risk of damaging the batteries, the instrument must be immediately powered from an AC power source or the power switch placed in the "OFF" position if the "HALT" message is displayed. Damage to the batteries is not covered under warranty.

WIRING TO REMOTE SENSOR ENCLOSURE

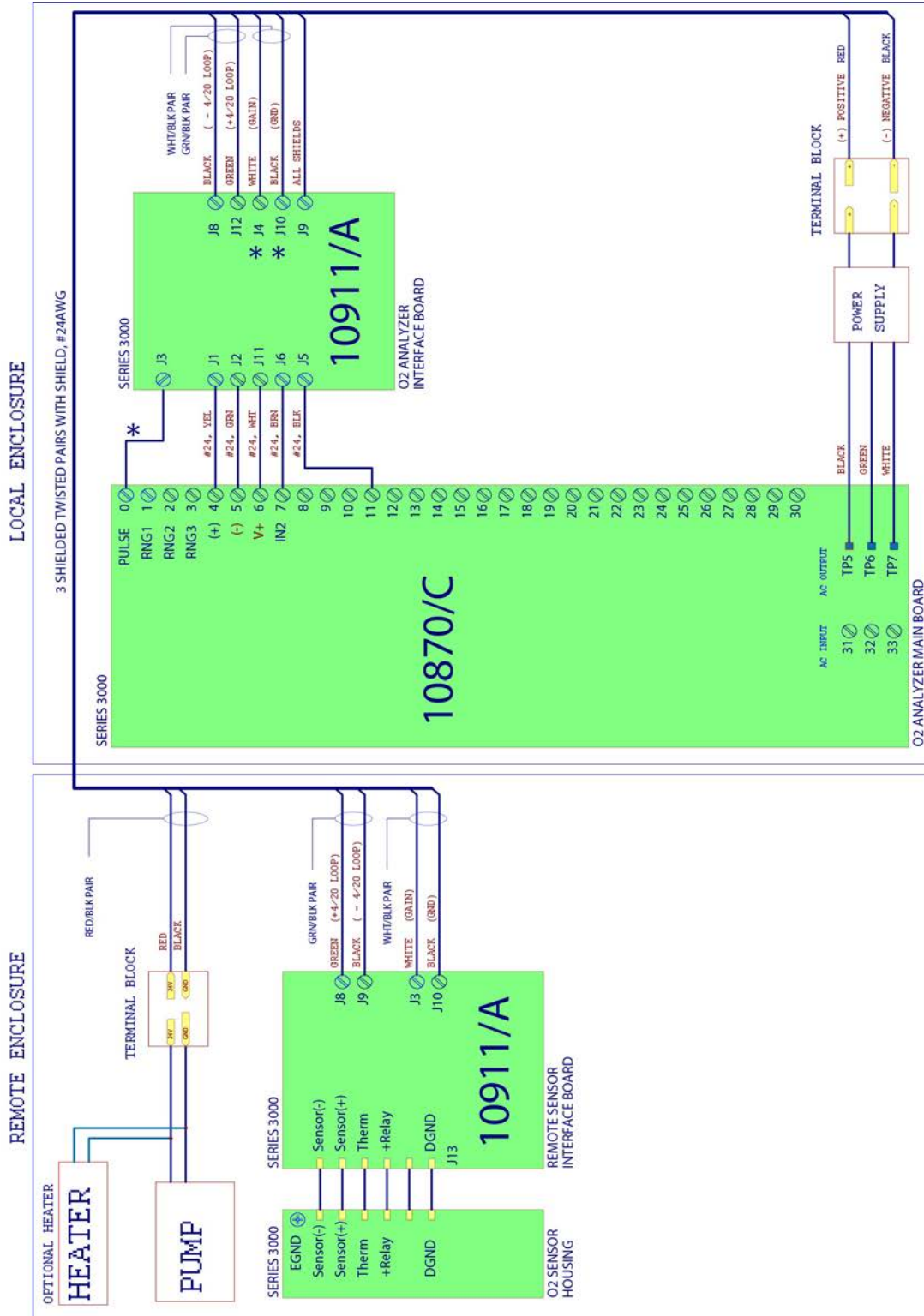

FIGURE 5.0

Alpha Omega Instruments, Corp.

\* Multi-range Units only

## 5.2 Operating Procedures

### 5.2.1 Power ON

To apply power to the analyzer, insert the AC plug and turn on the power switch located on the side of the analyzer. The Series 3000 Trace Oxygen Analyzer has battery backed RAM so when the instrument undergoes a cold start, all values, set by the user via the front panel or optional RS-232C and RS-485, will be maintained if switch #8 has previously been set to the "ON" position, otherwise referred to as the user configuration mode (See section 3.3). The cold boot gives the user the opportunity to make sure the microprocessor, internal memory, front panel LED's, and the audible alarm are functioning normally. During a cold start sequence, the instrument's front panel liquid crystal display (LCD) will display a series of dashes in series like [ \_ \_ \_ \_ ] [ - - - ] [ \_ \_ \_ \_ ], each of the three front panel LED's will blink simultaneously for approximately 5 seconds, and the audible alarm will sound intermittently for as long as the LED's are blinking. After this, the display will briefly show the onboard switch settings such as [ | | | | | | | ]. In this example, switch #8 is ON and all the others are in the OFF positions.

To perform a warm boot and read the internal switch settings, make sure SW6 - switch # 8 is "OFF" and push the front panel UP, DOWN, and Alarm 3 buttons simultaneously. Do not hold the buttons down very long after the display shows the dashes described above. You will see the same sequence as above, however, switch #8 will indicate low. Powering on with switch #8 in the "OFF" position will cause the Series 3000 Trace Oxygen Analyzer to default to the specific switch settings.

### 5.2.2 Front Panel Controls and Indicators

The front panel of the Series 3000 Trace Oxygen Analyzer contains a 4 digit liquid crystal display (LCD), three (3) alarm set push-button switches, three alarm LED's, and up and down push-button switches.

**Liquid Crystal Display:** The primary function of the LCD is to display the concentration of oxygen in the sample being measured in terms of parts per million by volume (ppm). Within approximately five seconds after a cold start, the Series 3000 Trace Oxygen Analyzer will measure and display the oxygen concentration of the sample gas exposed to the sensor. In addition to displaying oxygen values, the LCD indicates certain status levels. When setting an oxygen alarm value, it is also possible to toggle the alarm from high to low to high, etc. The display will show [ HI ] or [ LO ] very briefly upon pressing the up and down arrows simultaneously, indicating either a high or low alarm. Note: this is a toggle function, so if it shows the opposite setting desired, just toggle it back. Then exit the alarm set routine by pressing an alarm button. When the Series 3000 is equipped with the Battery Option, the LCD will display [ <sup>LOBAT</sup> ] when battery power has reached the point when normal instrument operation is in jeopardy. **To protect important information stored in the analyzer's memory [monitor's memory], the analyzer [monitor] suspends operation of the microprocessor when further operation could corrupt that memory. The microprocessor displays the word HALT on the LCD, then suspends further operation. The microprocessor does not resume operation until power is reapplied and the battery voltage is verified to be high enough to safely take over operation for a short time in the event of a recurring power failure.**

When calibrating the Series 3000 Trace Oxygen Analyzer, you will notice that upon initiating that mode, the liquid crystal display momentarily reads [ CAL ] and then the value of the oxygen concentration of the gas being measured is displayed. For further information on calibrating the analyzer, please refer to Section 6.0.

**Oxygen Alarms:** The Series 3000 Trace Oxygen Analyzer is equipped with three (3) oxygen alarms. All are set at the factory as high alarms. Any one of these alarms can be set by the user for operation as high alarms also. Please refer to Section 5.2.3 "Setting the Alarms" for instructions on how to set Alarm 3 for either high or low operation. Note: All alarms are user configurable via SW-6, - switch #8 (refer to section 3.3).

### **5.2.3 Setting the Alarms**

Assuming that no alarms are currently activated (no led's are lit), press the desired alarm switch on the front panel, "Alarm 1", "Alarm 2", or "Alarm 3" . The numerical value in the LCD is the existing alarm value associated with that alarm channel. When the alarm switch is pressed, the LED directly above the switch will light indicating that channel is in the alarm set mode. Any of the three Oxygen Alarms can be changed from low to high or vice versa by pressing the up and down arrows simultaneously. When the arrows are pressed simultaneously, the LCD will momentarily display the state of the alarm by indicating "LO" for low alarm and "HI" for high alarm and then resume displaying the actual alarm value.

To set the oxygen alarm values, using the front panel up and down arrows press the down arrow to lower the oxygen alarm value or the up arrow to increase the value. The longer either arrow is held down, the more rapidly the alarm values will scroll in the display. When the value in the display is close to the desired oxygen set point value, it is recommended that pressure be released from the switch. To obtain the final value, apply momentary pressure to the switch to change values in small increments. When finished setting the alarm, press the associated alarm switch. The LED will go off, and the display will indicate the actual oxygen concentration. If more than one alarm value is to be changed, repeat this procedure using the desired alarm channel.

### **5.2.4 Alarm Processing:**

When an alarm event takes place, several indications are provided by the Series 3000 Trace Oxygen Analyzer including:

1. The LED associated with the oxygen channel in question will light.
2. An audible alarm will sound.
3. The relay associated with the oxygen alarm in question will change state.

There are two possible conditions that effect the way the instrument will respond to alarm cancellation. One is auto-clear operation and the other is manual clear. The mode of operation is determined by the setting of SW-6 -switch #6.

#### **5.2.4.1 Auto-Clear Operation**

In the Auto Clear mode (SW-6 switch #6 is ON), the monitor will automatically reset the 3 indications mentioned above when the alarm condition clears. Whenever an alarm is active, pressing the associated front panel push-button (Alarm 1, Alarm 2, or Alarm 3) will silence the audible alarm. To change the setting for this same alarm, press the button a second time. If more than one alarm is on, the audible will still be canceled. Please note that the Series 3000 Trace Oxygen Analyzer will not go into an alarm set mode if an audible alarm is on for that alarm channel. It will for the other channel(s) that are not in an alarm mode. If, however, you push the alarm button twice for a channel that is in an alarm condition, it will allow you to change that alarm set point. If you set the alarm to a value that causes an alarm condition, the audible alarm will immediately come on upon exiting the alarm set mode.

**Note:** Under Auto-Clear operation, the silenced audible alarm may automatically come back on if the O<sub>2</sub> reading should go out of alarm range and then back into alarm condition. Also, after silencing the audible alarm, all alarms must be cleared to re-enable the audible alarm.

#### **5.2.4.2 Manual Clear Operation**

When SW6 switch #6 is in the "OFF" position, the Series 3000 Trace Oxygen Analyzer is in the Manual Clear mode. In the manual clear mode, whenever the Series 3000 Trace Oxygen Analyzer senses an alarm condition, it will be indicated by the 3 indications listed in Section 5.2.4. However, if the oxygen level should return to a non-alarm level, the monitor **will not** automatically clear. The user must first cancel the audible alarm by pushing the appropriate alarm button. Only after the audible alarm has been canceled can the user clear the alarm condition by again pushing the appropriate alarm button. If the set- point is to remain the same, simply pushing the appropriate alarm button a third time will clear the alarm.

**Note:** If the audible alarm is activated, pressing any alarm button that is not associated with an alarm condition, will temporarily quiet the audible alarm. Upon exiting the alarm set condition or if the monitor times out because of no user input, the audible alarm will resume awaiting a manual clear operation as described above.

#### **5.2.4.3 Timing Out**

If the user is setting the alarm(s) in the Series 3000 Trace Oxygen Analyzer and no adjustment has been made for approximately 2 minutes, the analyzer will automatically revert back to normal operation. This feature helps to prevent the user from inadvertently keeping the analyzer off-line for a prolonged period of time. If the user is in an alarm setting sequence and the instrument times out, the alarm value will be that which was last displayed in the LCD. However, under the calibration mode, if the instrument times out, no changes to the calibration settings will take place.

#### **5.2.5 Over Range**

If the oxygen concentration of the gas being measured by the Series 3000 Trace Oxygen Analyzer exceeds the highest range of the instrument, the LCD will show "OL" signifying an overload condition and the audible alarm will sound. The alarm can be shutoff at any time using any of the front panel switches. If left on, it will automatically shutoff once the oxygen concentration has dropped within range of the analyzer.

#### **5.2.6 TTL Signals for Analyzers with Autoranging**

As is the case with single range analyzers, all three range analyzers are equipped with two full scale analog outputs, 4-20 mADC and 0-2 VDC. If a recorder, datalogger, PLC, etc. Will be used to monitor the analog output (s) of the Series 3000 Trace Oxygen Analyzer, TTL (transistor transistor logic) signals are available to indicate (to the interface device) which of the three oxygen ranges is in use.

For example, a Series 3000 Trace Oxygen Analyzer equipped with three oxygen ranges of 0-50/500/5000 ppm, will provide simultaneous analog outputs of 12 mADC and 1 VDC when the oxygen value is 25 ppm, 250 ppm or 2500 ppm. Without use of the TTL signals, the interface device cannot distinguish which range is in use. RNG1 represents the lowest of the three ranges, with RNG2 and RNG3 representing the middle and high range respectively. The signals are accessible via three terminals labeled (RNG1, RNG2 and RNG3) near the top of the main output connector of the Series 3000 Trace Oxygen Analyzer (see figure 1.0). A **high** TTL signal indicates the specific range in use. When the lowest range is in use, RNG1 will be high (>2.8 VDC), and RNG2 and RNG3 will be low (<0.8 VDC). When the middle range is in use, RNG2 will be high with RNG1 and RNG3 indicating low, and when the high range is in use, RNG3 will be high with RNG1 and RNG2 indicating low.

### **5.2.6.1 Manual Range Changing**

The Series 3000 Trace Oxygen Analyzer can be configured to change the measuring ranges manually. Pressing Alarm 1 & Alarm 3 keys simultaneously enables the analyzer to briefly display the existing range setting. The default setting from the factory is **[Auto]**. This is a toggling function, therefore to cycle the available ranges, simply continue to press the Alarm 1 and Alarm 3 keys simultaneously until the range desired is shown in the display. As an example, if a Series 3000 Trace Oxygen Analyzer is equipped with three ranges consisting of 0-1/10.0 /100.0 ppm. pressing A1 and A3 simultaneously would produce a temporary range indication on the front panel.

Press A1 and A3 simultaneously	Display reads: [100.0]	
Press A1 and A3 simultaneously	Display reads: [10.0]	
Press A1 and A3 simultaneously	Display reads: [1.00]	
Press A1 and A3 simultaneously	Display reads: [Auto]	
Press A1 and A3 simultaneously	Display reads: [100.0]	Cycle Repeats.

When operating in manual mode (any range other than **[Auto]**), the instrument will display an **[OL]** condition if the oxygen concentration in the sample gas has gone beyond the active operating range of the instrument.

### **5.2.7 Gas System Pressure Limits**

For sample gases and/or calibration gases that are under pressure, it is imperative that the input pressure to the sensor be kept to under 1 pound per square inch. If the pressure is expected to be in excess of 1.0 psi, it is advisable to use a pressure regulator. Flow rates to the analyzer should be between 0.5 to 1.0 liters per minute, never to exceed 2.0 liters per minute. If the sample pressure is insufficient to move the gas through the sensor housing, a sample pump may be required (Alpha Omega Instruments P/N 3PMP or 3PMPH).

### **5.2.8 Sample Connections**

All Series 3000 Trace Oxygen Analyzers are equipped with 1/4 inch stainless steel compression fittings on both the sample inlet and outlet to the sensor housing. In addition, the necessary hardware for terminating to standard tubing is supplied. For all applications, stainless steel tubing is recommended. The Series 3000 Trace Oxygen Analyzer may be operated without any connections to the output of the sensor housing. Unless the sample gas is toxic or explosive in nature, it is common for the gas to be vented to atmosphere. Another precautionary measure should be taken if a high capacity pump is being used. In such cases, be sure to regulate the gas flow through the sensor using the downside isolation valve discussed in the following section.

**NOTE: ALL EXPLOSION PROOF ANALYZERS ARE EQUIPPED WITH INLET AND OUTLET GAS FLAME ARRESTORS. DO NOT REMOVE THESE ARRESTORS AS DOING SO MAY PRODUCE A POTENTIALLY HAZARDOUS CONDITION AND INVALIDATE THE INSTRUMENT WARRANTY.**

### **5.2.9 Isolation Valves**

For applications where the Analyzer will be used on an intermittent basis rather than continuously on-line, it is important to use the isolation valves that have been installed on the instrument. The valves will protect the sensor from exposure to air during times when the instrument is not in use. Just prior to taking the instrument off line, it is advisable to shut off the gas flow to the instrument, shutting the inlet valve off first followed immediately by the outlet valve (shutting the inlet valve first avoids inadvertently over pressurizing the sensor). Assuming the gas that was flowing through the sensor housing contained trace levels of oxygen, this will help minimize exposing the sensor to air. When reconnecting the instrument to a sample gas line, just prior to starting the sample flow, open the outlet valve followed by the inlet valve.

## Section 6.0 CALIBRATION PROCEDURES

### 6.1 Initial & Routine Calibration Checks

All Series 3000 Oxygen Trace Oxygen Analyzers are fully calibrated at the factory prior to shipment. However, with the potential hazards associated with shipping instrumentation, it is advisable that the analyzer be given a system calibration check at the time of startup. Alpha Omega Instruments trace oxygen sensors features high accuracy and excellent long term stability characteristics. As a result, routine maintenance is kept to a minimum. As is the case with all gas analyzers, it is advisable to periodically check the overall system calibration. The frequency of these checks is often determined by in-house calibration protocols. If none exists, Alpha Omega Instruments Corp. recommends that a calibration check be made on an average of once every 2-3 months.

#### 6.1.2 Calibration Gas

The oxygen sensor used in the Series 3000 Trace Oxygen Analyzer has a linear output. As a result, it can be calibrated using a single calibration gas as long as the test is performed accurately. The calibration gas should contain a defined concentration of oxygen with a balance of nitrogen (N<sub>2</sub>). The actual concentration of oxygen should be chosen based on the range(s) of the instrument. For single range analyzers, choose a calibration gas that is somewhere between 30%-70% of the analyzer's range. For instance, if the analyzer has a range of 0-1,000 ppm, it is advised that the calibration gas should have an oxygen concentration between 300-700 ppm/balance N<sub>2</sub>. For three range analyzers, use the same rule of thumb choosing the range most often used as the basis for selecting the calibration gas. As an example, if the analyzer has three ranges consisting of 0-10/100/1,000 ppm and the 0-100 ppm is the most often used range, the calibration gas selected should have an oxygen concentration between 30-70 ppm/balance N<sub>2</sub>. Most major gas manufacturers can readily supply calibration gases.

#### 6.1.3 Procedure for Checking Calibration

1. Select a cylinder of calibration gas as described in Section 6.1.2.
2. When selecting a pressure regulator to use with the cylinder gas, it is advisable to use a two-stage regulator with the second stage capable of delivering a gas sample at a pressure of under 1.0 PSIG. Also, be sure to choose a regulator with a metal diaphragm, preferably stainless steel.
3. In addition to the selection of the pressure regulator, care must be given to choose the correct sample tubing materials. For trace oxygen measuring applications, stainless steel tubing should be used. An alternate choice is copper.



**DO NOT USE RUBBER OR PLASTIC TUBING. AIR CONTAINS 209,000 PPM OF OXYGEN. A MINUTE LEAK OF AIR INTO THE EITHER THE CALIBRATION GAS OR SAMPLE GAS LINE CAN CAUSE SIZABLE ERRORS IN READINGS. LEAKAGE CAN BE THROUGH CRACKS IN THE TUBING OR BY DIFFUSION THROUGH THE TUBING.**

4. If not already equipped with one, install a flow meter on the discharge side of the sensor. Being on the downside of the sensor, the materials of construction are of no significance to the readings obtained so acrylic flow meters are permissible.
5. Power up the Series 3000 Trace Oxygen Analyzer as described in Section 4.2. and set the calibration gas flow rate to 0.5 liter per minute (LPM). Monitor the analyzer response to the calibration gas, waiting until a stable reading has been established. (The use of a recorder or



- data logger can be very helpful in verifying that the analyzer has reached an equilibrium point.).
6. Once the reading has stabilized, check the system for gas leaks. This is best done when step 5 has been completed. An easy method of determining the leak integrity of the system is to vary the flow rate of the calibration gas. If increasing the flow rate from 0.5 LPM to 1 LPM causes a drop in the reading, there is a good chance that somewhere between the gas source and inlet to the sensor there is a leak. Check all gas fittings, connections, etc. using Snoop liquid leak detector (Snoop is a registered trademark of NUPRO Co., 4800 East 345th Street, Willoughby, Ohio 44094).
  7. The reading in the LCD should now display the oxygen concentration of the calibration gas. **BE SURE TO ALLOW THE READING TO COME INTO EQUILIBRIUM BEFORE MAKING ANY ADJUSTMENTS.**
  8. If the oxygen value read from the LCD differs from the calibration gas, a span adjustment should be made so that the value displayed in the LCD is identical to that of the calibration gas. If a span adjustment is to be made, the instrument must be placed in the calibration mode. To do so, **simultaneously** press the front panel buttons labeled Alarm 1, Alarm 2, and Alarm 3. The meter will alternately blink between "CAL" and the oxygen value in the LCD to let the user know that the analyzer is in the calibration mode. If the oxygen value displayed is lower than the calibration gas value, press the up arrow to adjust the value in the LCD upwards. Conversely, if it is higher, use the down arrow to lower the reading. When finished, once again press Alarm 1, Alarm 2, and Alarm 3 buttons **simultaneously** and the display will stop blinking, indicating the calibration sequence has been completed. If after initiating a calibration sequence, it is decided not to make an adjustment, allow the instrument to time out (2 minutes). In doing so, the previous calibration settings will be used.



The Series 3000 Trace Oxygen Analyzer is equipped with a fourth alarm relay, referred to as an Instrument Status Alarm. The primary function of this relay is to alert users when a sensor needs to be changed. During calibration, if the amount of gain (calibration adjustment) has exceeded a predetermined limit set at the factory, a message will be shown across the LCD "change sensor". This message will be displayed only when the instrument has been taken out of calibration mode. In addition to the message, the instrument status alarm will actuate. If this is the first warning, in all likelihood, the instrument will still function normally. However, it is an indication that the sensor should be replaced as soon as possible. Though the change sensor message will only be displayed once per calibration cycle (when the preset gain has been exceeded), the alarm relay will stay in the alarm state until the condition has been cleared. Clearing of the alarm condition requires changing the sensor.

**6.1.3.2 Zero Adjustment**

As discussed in Section 3.0, Alpha Omega Instruments' trace oxygen sensor is very specific for oxygen. When there is no oxygen present, the output from the sensor is zero. This coupled with the inherent linear characteristics of the sensor allow the user to use a single point calibration as means of calibrating the system. **NO ZERO CALIBRATION IS REQUIRED.**

Section 7.0  
REPLACEMENT OF THE OXYGEN SENSOR

7.1 Procedure for Replacing the Oxygen Sensor

Alpha Omega Instruments oxygen sensor is designed to operate for prolonged periods of time without replacement. However, in time the sensor's output will drop to a level where replacement becomes the prudent course of action. A good indication of this is a marked increase in calibration frequency. When this happens, a replacement sensor should be ordered directly from the factory.

To install a new sensor follow the directions below (applies to all non-explosion proof systems):

1. Remove all power (AC or DC) from the instrument.



**IT IS ADVISABLE TO KEEP A LOW PPM GAS FLOWING THROUGH THE SENSOR HOUSING WHILE THE SENSOR IS BEING REPLACED. IT IS IMPORTANT THAT WHEN A NEW SENSOR IS INSTALLED, THE TIME BETWEEN WHEN IT WAS UNPACKED AND FIRST EXPOSED TO CALIBRATION GAS SHOULD BE KEPT TO AN ABSOLUTE MINIMUM. THE AMOUNT OF TIME TAKEN TO ACHIEVE THE GAS CALIBRATION LEVEL IS A FUNCTION OF HOW LONG THE SENSOR WAS EXPOSED TO AIR DURING REPLACEMENT. WHEN A NEW SENSOR IS INSTALLED, IT MAY TAKE APPROXIMATELY ONE HOUR TO REACH EQUILIBRIUM ON A CALIBRATION GAS.**

2. Locate the sensor housing. For portable and certain panel mounted configurations, the sensor housing is located on the rear of the instrument. For remote sensor enclosures, the sensor housing is mounted to the remote enclosure, and for explosion proof systems, the sensor housing is mounted within the explosion proof enclosure.
3. If the enclosure to which the sensor housing is attached is permanently mounted and, the gas lines are rigidly installed, it will be necessary to disconnect both gas inlet and outlet lines.
4. With one hand supporting the sensor housing, loosen (do not remove) the four servo clamp screws that hold the stainless steel ring to the enclosure. The sensor housing will drop from the enclosure.
5. Disconnect the modular connector at the top of the sensor housing.
6. Remove the screws that hold the two halves of the sensor housing together. Once these screws have been removed, the two halves should easily separate.



**WHEN SEPARATING THE TOP OR INNER HALF OF THE SENSOR HOUSING FROM THE BOTTOM OR OUTER HALF, NEVER TWIST THE TWO AS THIS WILL CAUSE DAMAGE TO THE SPRING LOADED PINS. BE CAREFUL NOT TO BEND THESE PINS WHEN THE SENSOR HALVES ARE APART.**

7. Remove the old sensor from the bottom half of the sensor housing.



**THE SENSORS CONTAIN A SMALL AMOUNT OF CAUSTIC ELECTROLYTE. WHEN DISCARDING SPENT SENSORS, CARE SHOULD BE GIVEN NOT TO PUNCTURE THE SENSOR OR TAKE IT APART. DISCARD THE SENSOR ACCORDING TO LOCAL STATE OR COUNTY GUIDELINES.**

8. Remove the existing O ring and examine the grooves in the upper and lower halves of the sensor housing to be sure they are clean. Replace the O ring with the new one supplied with the sensor.
9. Remove the new sensor from its package. Before installing it in the lower half of the sensor housing, REMOVE THE CAP and then install the sensor with the two gold rings facing outward from housing.
10. Take the two halves of the sensor housing and align them so the socket head screws can be reinstalled. Hand tighten the socket head screws being careful to do so evenly.
11. Reconnect the gas lines and begin processing gas through the sensor housing.
12. Apply power and calibrate according to Section 6.1.3.

**SECTION 8.0  
Optional Serial Communications RS232C & RS485**

**8.1 Baud Rates**

Available Baud Rates are 38400\*, 19200\*, 9600, 4800, 2400, 1200, 300, and 150. To set the baud rate please follow the directions below, in the sequence given:

1. Be sure that the unit is fully operational. You can check this by observing that valid oxygen readings are displayed on the front panel LCD of the instrument.
2. Next, make sure that switch 5 on the Main board Switch Bank is LOW or OFF. This is a factory switch and should be on only in certain circumstances. Note: if the unit was shipped with SW5 ON, turn it off to set the baud rate. After the baud rate has been set, move SW5 to the on position to resume normal operation.
3. Press and hold the UP and DN keys simultaneously. An initial beep will be heard followed by a second beep which confirms that the next step should be taken.
4. At this point, the current setting should be displayed on the front panel. If not, make sure that you hold the two aforementioned keys long enough.
5. Now press and hold the UP and DN keys to scroll through available settings choosing the desired baud rate.

With the desired baud rate displayed, push the Alarm 3 button to save it in battery backed memory

**8.2 Standard Commands**

The following standard commands apply for both the RS-232C OR RS-485 interfaces:

Please note that all letters typed can be upper or lower case. The only exception to this rule is the optional [string]. The Commands below are in upper case for clarity purposes only. Also any user input not in brackets is shown in lower case. Optional commands or strings are shown within brackets.

<b>Command</b>		<b>Description</b>
Aa=[bb.b][L/H]	<Enter>	Alarm set
Bcccc	<Enter>	Baud rate select
C[bb.b]	<Enter>	Calibrate
D[string]	<Enter>	Disable Security
E[string]	<Enter>	Enable Security
FSd=[ON/OFF/1/0]	<Enter>	Fail-safe select
H	<Enter>	Help Screen
M	<Enter>	Manual clear toggle
O	<Enter>	Oxygen Concentration
Q	<Enter>	Quiet mode (no beeps at all)
S	<Enter>	Signal mode (beeps audible)
V	<Enter>	View current Alarms and settings

Where:

- a=1, 2, or 3 for different alarms
- bb.b = Decimal number signifying the oxygen in PPM
- L/H = Optionally set to 'L'ow or 'H'igh alarm
- cccc = Baud rate number from 150 to 38400 (as shown in 8.1 above)
- d = Number designating Relay 1 to 4
- ON/OFF/1/0 = 'ON' is the same as '1' etc.
- name = String for accessing multiple units (see manual)
- string = String for security protection (see manual)

---

\* Baud Rates not available on RS485

An example of each command is as follows:

**'A' Command** - Alarm set point with low or high alarm option.

Alarm #1 will be set to go off in the case of the oxygen level dropping below 20 ppm. Type:

**A1=20.0L <Enter>**

To change Alarm #1 to 18 ppm instead of 20 ppm you could type:

**A1=18 <Enter>**

Note how the 'L'ow alarm is optional unless changing to 'H'igh? As you can see, the decimal point is optional too, and if left out defaults to '.0'. Note how the command in the help screen says, "[bb.b]&/or[L/H]"? Examine the following example:

**A1=H <Enter>**

This is a valid command and will only effect the 'L'ow or 'H'igh status of Alarm 1. To set it back to a low alarm type:

**A1=L <Enter>**

**'B' Command** - Baud change. To change the baud from 300 bps (default) to 9600 bps type the following:

Make sure the instrument is responding at 300 bps first.

**B9600 <Enter>**

Note that you may have some garbled data output. Now you must change your terminal's baud rate and reestablish communication by pressing <Enter>.

**'C' Command** - Calibrate to known calibration standard (i.e. 40 ppm).

Using a calibration gas consisting of 40 ppm, type the following:

**C40 <Enter>**

**'D' Command** - Disable security with optional pass code. (See 'E' Command below for description of security)

In it's simplest form, to disable security protection type:

**D <Enter>**

Assuming an 'E' Command had been sent with a pass code of "mypass1" (see next command example) then type the following to disable the security option:

**Dmypass1 <Enter>**

Note: typing "DMYPASS1" will not disable the instrument if the original pass code was in lowercase! That means that the 'D' and 'E' commands are CASE SENSITIVE.

**'E' Command** - Enable security with optional pass code.

To keep others from changing any system settings, the 'E'nable Command is supplied as an optional security measure. In it's simplest form type the following:

**E <Enter>**

In this example, the user would just type 'E' by itself. This would keep people from inadvertently changing the system settings. However, if the need should arise to change a setting, all that would be necessary would be a 'D' command with no pass code. The following command shows the use of a pass code:

**Eypass1 <Enter>**

This will arm the security system and will ignore any requests for system changes until the user disarms the system with a 'D' Command followed by the correct pass code (See 'D' command above).

**'FS' Command** - Fail-safe select.

If the alarm relays should be energized in normal operation and release in the case of a power failure, type the following:

**FS1=ON      <Enter>**  
**FS2=1        <Enter>**  
**FS3=on       <Enter>**  
**fs4=On       <Enter>**

Note the individual control over each alarm. Also, ON/on/OFF/off or 1/0 can be used to control the status of each. Commands are not case sensitive. Example: If only Alarm 2 needs to be in Fail-safe mode, then type:

**FS1=off      <Enter>**  
**FS3=0        <Enter>**  
**FS4=Off      <Enter>**

This turns off the Fail-safe mode for Alarms 1, 3, and 4.

**'H' Command** - Help Screen

Displays a help screen.

**H <Enter>**

**'M' Command** - Manually clear all alarms.

This command toggles between 'M'annual and Automatic clearing of alarms. The clearing of an alarm is simply when the condition causing the alarm has been corrected and the Series 3000 gives no indication that the alarm was on.

**'O' Command** - Output Oxygen Concentration

This command is useful for a quick reading of the Oxygen Concentration. All that is returned is the present reading in trace oxygen.

**'Q' Command** - Quiet mode (disables the audible alarm. Warning! This disables all sounds - even from alarms!)

If the instrument is going to be in a test mode for a while, with sensors being removed and replaced (causing a lot of harmless alarms), you can optionally remove the beeping altogether by typing:

**Q <Enter>**

This will stay in effect until an 'S' command is received by the Series 3000, or a re-boot is initiated. A message will appear under the 'V' command displaying the current mode.

**'S' Command** - Signal mode (enables the audible alarm).

To allow the audible alarms to be heard, simply type the following:

**S <Enter>**

**'V' Command** - View current alarms and settings

To view the current status of the Series 3000, type:

**V <Enter>**

Typical Response:

Alarm Settings

<b>#1:(HI) 22.0</b>	<b>Fail-safe: OFF</b>
<b>#2:(LO) 19.0</b>	<b>Fail-safe: OFF</b>
<b>#3:(LO) 10.0</b>	<b>Fail-safe: ON</b>
<b>#4: N/A</b>	<b>Fail-safe: OFF</b>

**Oxygen Level = 21.0 ppm**

**Alarm 1 is ON Relay 1: Energized**  
**Alarm 2 is OFF Relay 2: De-energized**  
**Alarm 3 is OFF Relay 3: Energized**

**Conditions**

<b>AC inp: ok</b>	<b>4-20mA: ok</b>	<b>Open Collector output: off</b>
<b>Batt: ok (22)</b>	<b>Aux. Relay: De-energized</b>	
<b>Alarms to be cleared MANUALLY</b>		
<b>Signal Mode</b>		



Commands that affect the output of the 'V' command are as follows:

1. 'A' commands will update the Alarm Settings
2. 'FS' commands will update the Fail-safe settings on or off
3. 'Q' & 'S' commands will update the comment indicating the status of the 'Q'uiet / 'S'ignal mode
4. 'M' commands will toggle the word following the phrase, "Alarms to be cleared ", between 'manually' and 'automatically'.

Note: The number in parenthesis next to the Battery condition is simply the voltage detected by the battery circuit. This can be used for making sure the battery is fully charged.

### 8.3 RS232/485 Connections

Connect the Series 3000 to a terminal or computer as follows:

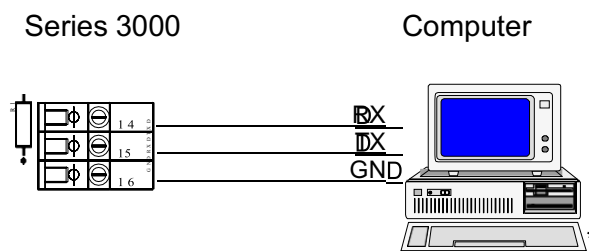

Note: If you have an RS485 output and have trouble communicating, try tipping over the input and output lines. Some are called T+ / T- or maybe A / B. Whatever the case, the communications link will not work unless these are correct.

SECTION 9.0  
Optional RS485 - Enhanced Remote Control Commands

9.1 General

Please read the section on RS232C first to familiarize yourself to the command structure. All commands under RS485 are either exactly the same or have slight enhancements over RS232C. This section is devoted to specifying only the enhancements associated with the RS485 protocol. Below is a sample 'H'elp Screen using the 'H' Command.

\Aa=bb.b[L/H]	<Enter>	Alarm set
\Bcccc	<Enter>	Baud rate select
\C[bb.b]	<Enter>	Calibrate
\D[string]	<Enter>	Disable Security
\E[string]	<Enter>	Enable Security
\FSd=[ON/OFF/1/0]	<Enter>	Fail-safe select
\Gcommand	<Enter>	Global set (be careful here)
\H	<Enter>	Help Screen
\L[name]	<Enter>	Local Name OR Number
\M[name]	<Enter>	Manual clear toggle
\O[name]	<Enter>	Oxygen Concentration
\Q[name]	<Enter>	Quiet mode (no beeps at all)
\S[name]	<Enter>	Signal mode (beeps audible)
\U[name]	<Enter>	Use analyzer with 'name' for all cmds
\V[name]	<Enter>	View current Alarms and settings

Where:

bb.b = Decimal number specifying oxygen in ppm  
L/H = Optionally set to 'L'ow or 'H'igh alarm  
cccc = Baud rate number from 150 to 9600  
d = Number designating Relay 1 to 4  
ON/OFF/1/0 = 'ON' is the same as '1' etc.  
name = String for accessing multiple units (see manual)  
string = String for security protection (see manual)  
command = Any valid command (**WARNING: G will act on all units!**)

Please note that there is an extra character - a backslash ('\') - before each command. This is necessary to avoid conflicts between individual Series 3000's."

You will notice that there are three new commands here. 'G'lobal, 'L'ocal, and 'U'se. The first one is the 'G' Command. As it states above, this is the 'G'lobal Set command. This command is very powerful and must be discussed in detail.

RS485 gives the user the ability to connect multiple Series 3000's together and communicate to them simultaneously. Therefore, it may become necessary or convenient to have certain Setpoints be 'G'lobally set. Instead of setting all instruments up one by one, use the 'G'lobal Command to control all Series 3000 units at the same time!

Each command will be discussed here, taking into consideration that there is most likely more than one unit to be controlled over the RS485 communications lines (twisted pair).

Please refer to Section 8.2 for information on the following commands.

'\A' Command - Same as RS232 without the backslash.  
'\B' Command - Same as RS232 without the backslash.  
'\C' Command - Same as RS232 without the backslash.  
'\D' Command - Same as RS232 without the backslash.  
'\E' Command - Same as RS232 without the backslash.  
'\F' Command - Same as RS232 without the backslash.  
'\H' Command - Same as RS232 without the backslash.

## **9.2 Special Commands for RS485**

**'G' Command** - Global Set command.

This command will cause all units tied into the RS485 communications line to respond to whatever command comes after it. For example, typing:

**\G <Enter>**

will do nothing! This is because no command was given after the 'G'. However, typing:

**\GA1=20.5h <Enter>**

will set up every Series 3000 connected to the RS485 line to have a High Alarm1 Setting of 20.5 ppm. Now let's try the 'G' command with the 'B' command for setting the baud rate. This is a handy little time saver! For instance, to set all units to 9600 bps just type:

**\GB9600**

Or in other words, "Global Baud 9600". Make sure you change your terminal baud rate after using a 'B' command.

Globally Calibrating is not allowed.

The next two commands function just like RS232C, only they function on all units connected to the communications line.

**\GD[string] and  
\GE[string]**

"Globally Disable" and "Globally Enable". Refer to RS232C section for more detail.

Note: Remember, if you are adding units to the RS485 line, and you don't make sure of your security codes, you could end up with multiple security codes! To be sure, have all units on line before enabling a global security code.

If you need all instruments to operate in the Fail-safe mode, just use the 'G'lobal command:

```
\GFS1=1 <Enter>  
\GFS2=1 <Enter>  
\GFS3=1 <Enter>  
\GFS4=1 <Enter>
```

Note how each Alarm is treated individually. The following commands are not available:

```
\GH <Enter> does nothing.  
\GI <Enter> does nothing.  
\GL <Enter> does nothing.
```

The next available 'G'lobal command would be the 'Q'uiet command. Note: No optional name is required and if supplied will cause the Series 3000 (if enabled) to respond with an 'Error!' message. (See description of 'Q' command below)

```
\GQ <Enter>
```

Preceding this command with the 'G'lobal command does exactly what you would expect. 'G'lobally 'Q'uiet all audible sounds. See the 'S'ignal command below for setting the audible sounds back to normal.

To make all alarms audible, type the following command:

```
\GS <Enter>
```

This puts all Series 3000's into 'S'ignal mode. This means that any alarm condition will result in an audible alarm signal. No other commands are available for 'G'lobal setting.

### **9.3 Added RS485 Enhanced Commands**

\L' Command - Local name assignment.

This command allows the user to name each Series 3000 that might be on the RS485 communications line. For instance, an example might be that there are two rooms that need to be monitored using a Series 3000 in each room. From the factory, the Series 3000 is set up to have a blank 'name'. This is equivalent to typing:

```
\L <Enter>
```

If the unit has been enabled using the 'U' command or has been set up to the factory default, the instrument will respond:

```
" O.K.
```

The unit's name is displayed in single quotation marks. Note how the name is blank above.

In our example, we want to put two Series 3000's on line. First connect ONE Series 3000 to the RS485 line, and get it up and running. After the unit is responding, type the following just as an example:

**\L Unit#1 <Enter>**

This comes back with a message stating:

**" changed to: ' Unit#1'**

**' Unit#1' O.K.**

You can substitute the above, "Unit#1" with any string you like. Usually the shorter the better for purposes of saving keystrokes when accessing the unit. Now type the following:

**\U <Enter>            See next command for description**

This basically 'disables' Unit#1 so we can talk to the next unit we put on the line. Now we are ready to add another unit. Connect the second Series 3000 to the line. If you haven't already, you may have to type 'L' followed by <Enter> (Factory Default) to communicate with the new unit that was just put on the line. (Note: if the unit does not respond then a factory boot may be necessary. To perform a factory boot which will return the unit to it's shipping state, push the UP, DOWN, and Alarm 3 buttons simultaneously as above while holding at least one button down. The button(s) pushed will very briefly show on the display( i.e. while holding the Alarm 1 button down the display will read [ A1 ] briefly ) until [[Fb]] shows up on the display. This means you have successfully performed a Factory boot. The instrument will then proceed to a normal warm boot to read the switch settings etc. - At this time you can name the second unit. Maybe it would look something like this:

**\L Unit#2 <Enter>**

**WARNING! If you put two or more units on an RS485 line with the same name and ask for output, anything can happen! You can change the currently responding unit's name, just don't set it to a name that currently exists because the next time you type "Uname", you will select two units at one time!**

**\U' Command** - Use command.

This command is used for selecting a different Series 3000 that has already been set up using the 'L' command. For instance, using the above example of Unit #1 and Unit #2, to access Unit #1 you would type:

**\U Unit#1**

You should get a response of:

**Using: ' Unit#1'**

Note the 'extra' space after the single quote at the beginning of the string. This is not mandatory and can be removed by renaming it using the 'L' command as follows:

**\LUnit#1 <Enter>**

Note: there is no space between 'L' and 'U'

## **9.4 RS485 Enhanced Commands**

**\M' Command** - Manual / Automatic clearing of alarms.

The enhancement to this command is using the 'name' as a variable. For instance, no matter what unit is enabled and responding to commands, you can address a specific unit for toggling this function as follows:

**\M#1 <Enter>**

If a unit with the 'name' "#1" assigned to it exists, then only that unit will act upon the command. Note: Only the unit that is enabled can respond via RS485, so when using this addressing scheme you may want to verify that the command was received by the specific instrument by giving it a 'V' name command (See below).

**\O' Command** - Output Oxygen Concentration

This command is useful for a quick reading of the Oxygen Concentration. All that is returned is the present reading in trace oxygen.

**\Q' Command** - Quiet Mode select

Same enhancement as above in that you can selectively 'Q'uiet any unit by following the command with a valid unit name.

**\S' Command** - Signal Mode select

Same enhancement as above.

**\V' Command** - View settings

This has the same enhancement as the 'M', 'Q', and 'S' commands and can be used to verify that each of those commands work properly. For example: With two units, one named "One" and the other named "Two" you could do the following:

**\UOne <Enter>**

This selects unit "One". Now lets check the status of unit "Two":

**\VTwo <Enter>**

We will just notice that part of the 'V'iew screen shows:

### **Alarms to be cleared MANUALLY**

Now try changing the MANUAL clearing to AUTOMATIC without 'U'sing unit #2:

**\MTwo <Enter>**

**\VTwo <Enter>**

Now we can see that the 'V'iew screen shows:

### **Alarms to be cleared AUTOMATICALLY**

Note that while we entered these commands the unit would respond to an <Enter> with:

**'One' O.K.**

That means you could set up all your parameters for unit "One" and still use the 'M', 'Q', and 'S' commands on other units without having to type "UTwo", then the desired command.

Note: It is possible to reconfigure the alarms temporarily via the front panel. This will only last as long as the power is on and no warm boot is performed. To save your front panel configuration, you **MUST** have Switch #8 in the "ON" position. This will cause the Series 3000 Trace Oxygen Analyzer to remember all user modified configurations.

**APPENDIX A**  
**BENCH TOP/PORTABLE CONFIGURATION**  
**PART NUMBER BTP**

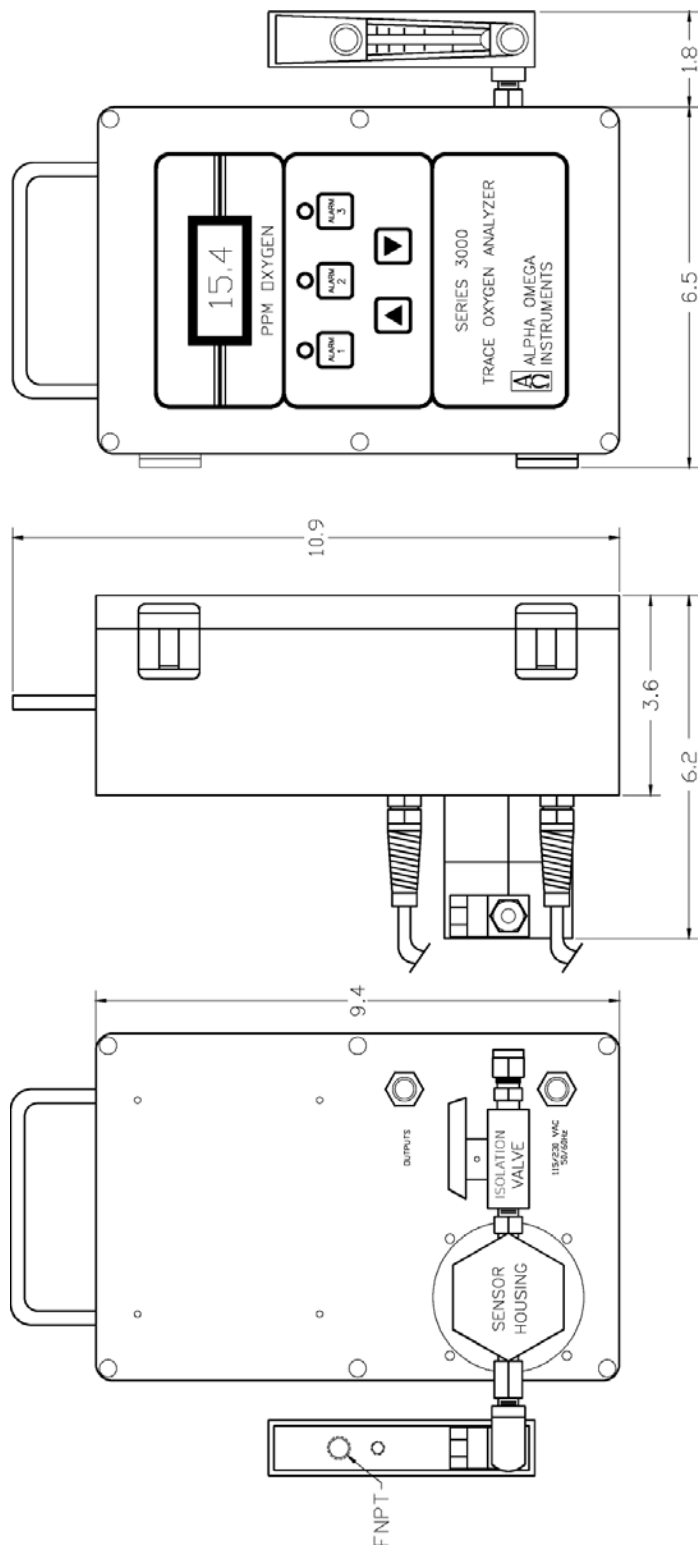

ALPHA OMEGA INSTRUMENTS CORP.		SERIES 3000		CONFIGURATION DRAWING	
DESIGNED BY	DATE	SIZE	PAPER NO.	DRAWING NO.	REV.
CHECKED BY	DATE			3000A	A
			PAGE 1 OF 1		



**APPENDIX B**  
**PANEL MOUNT CONFIGURATION**  
**ART NUMBERS PNL, PNR, & PTX**

**FRONT VIEW**

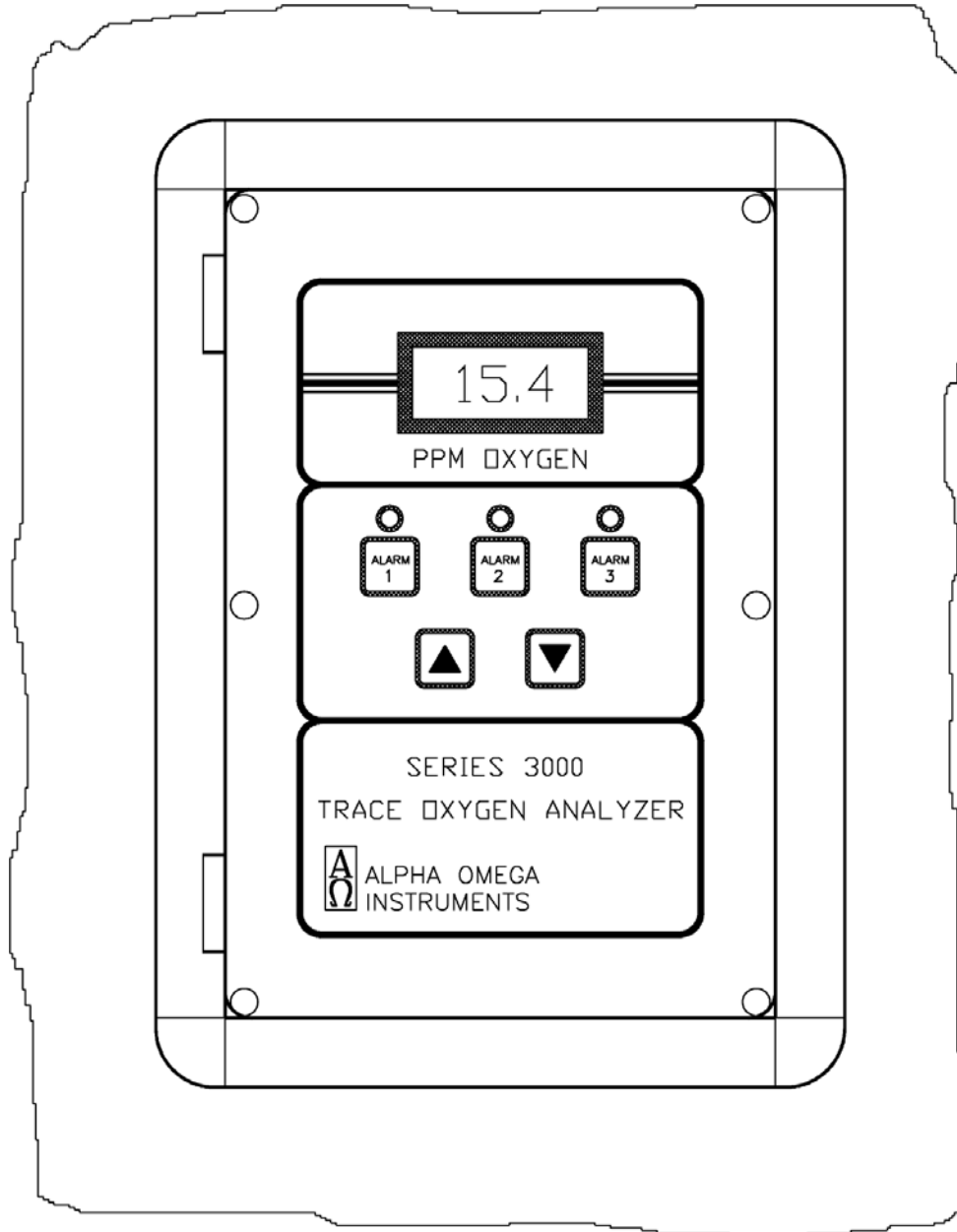

UNLESS OTHERWISE SPECIFIED: DIMENSIONS ARE IN INCHES TOLERANCES		ALPHA-OMEGA INSTRUMENTS CORP. 30 Martin Street Cumberland, RI 02864		Tel. (800) 283-8977 (401) 333-8800 Fax (401) 333-8800	
DECIMALS .XX ± .010 .XXX ± .005 DO NOT SCALE DRAWING		ANGULAR ± .05		SERIES 3000 CONFIGURATION DRAWING	
DRAWN	DATE	SIZE	FSOM No.	DRAWING No.	REV.
CHECKED	DATE			3000B	A
DESIGN	DATE	SCALE		SHEET 1 OF 1	

**APPENDIX B (continued)**  
**PANEL MOUNT CONFIGURATION**  
**PART NUMBERS PNL, PNR, & PTX**

**SIDE VIEW**

Customer Panel

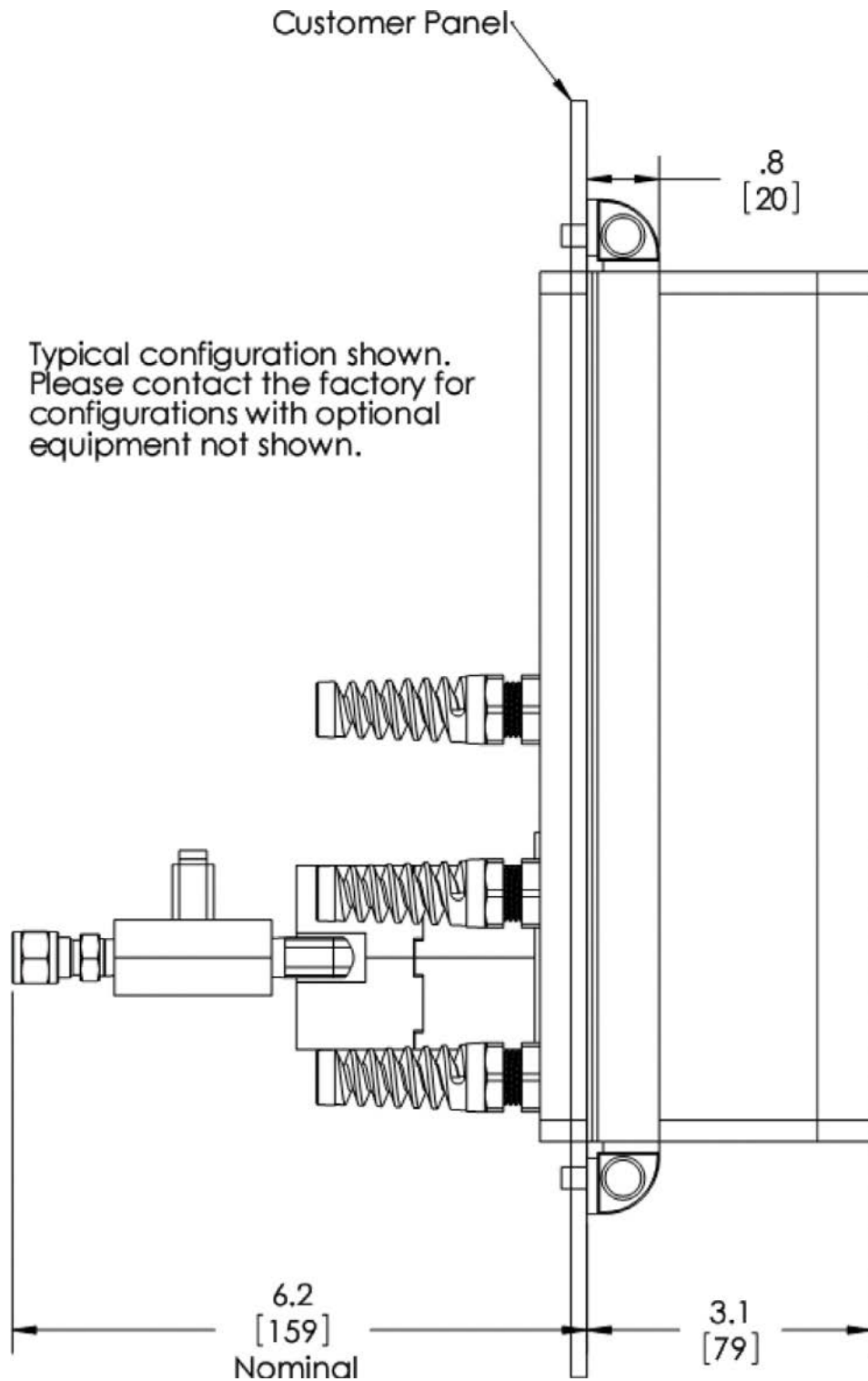

**APPENDIX B (continued)**  
**PANEL MOUNT CONFIGURATION**  
**PART NUMBERS PNL, PNR, & PTX**

**REAR VIEW**

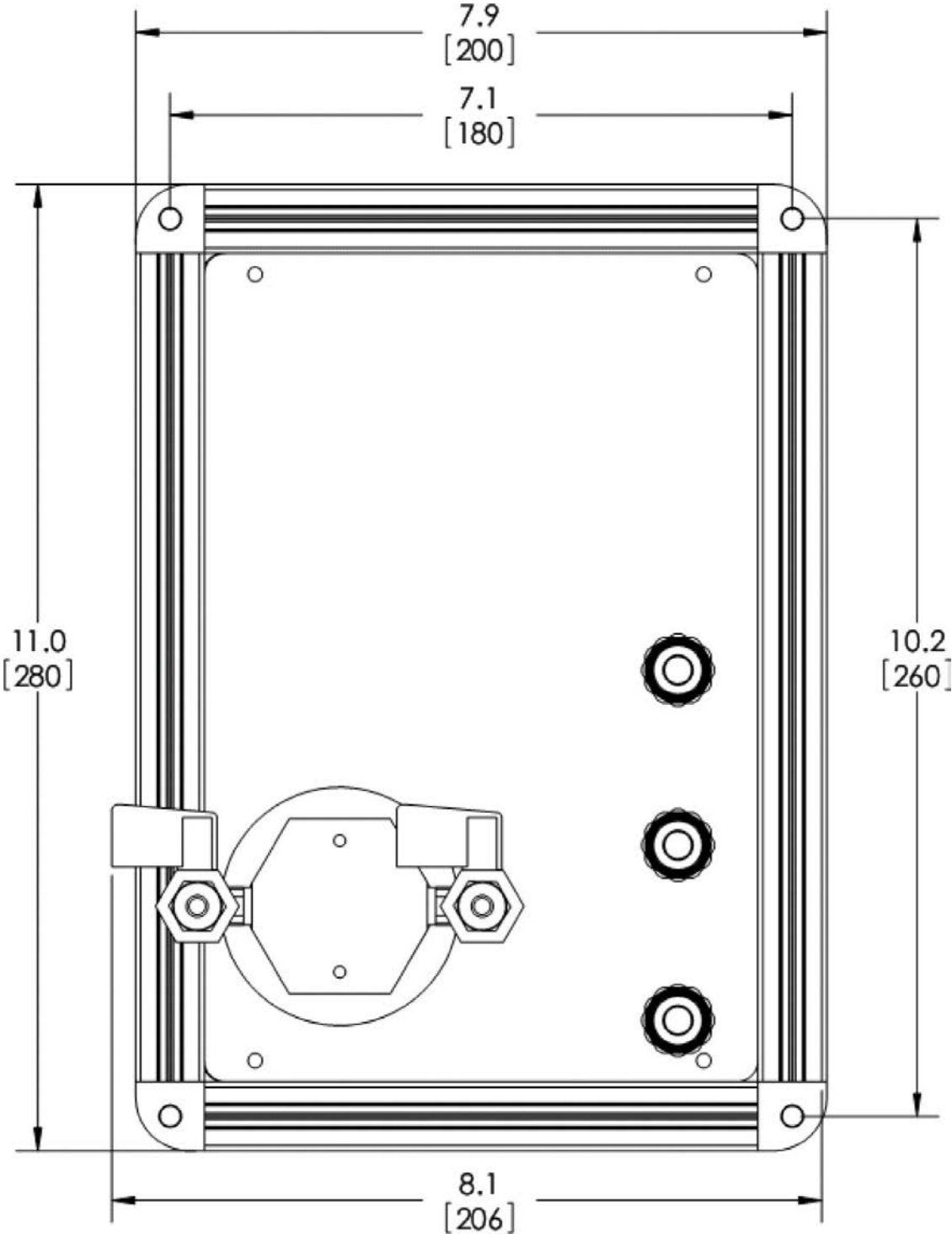

**APPENDIX B (continued)**  
**PANEL MOUNT CONFIGURATION**  
**PART NUMBERS PNL, PNR, & PTX**

**PANEL CUT-OUT DETAILS**

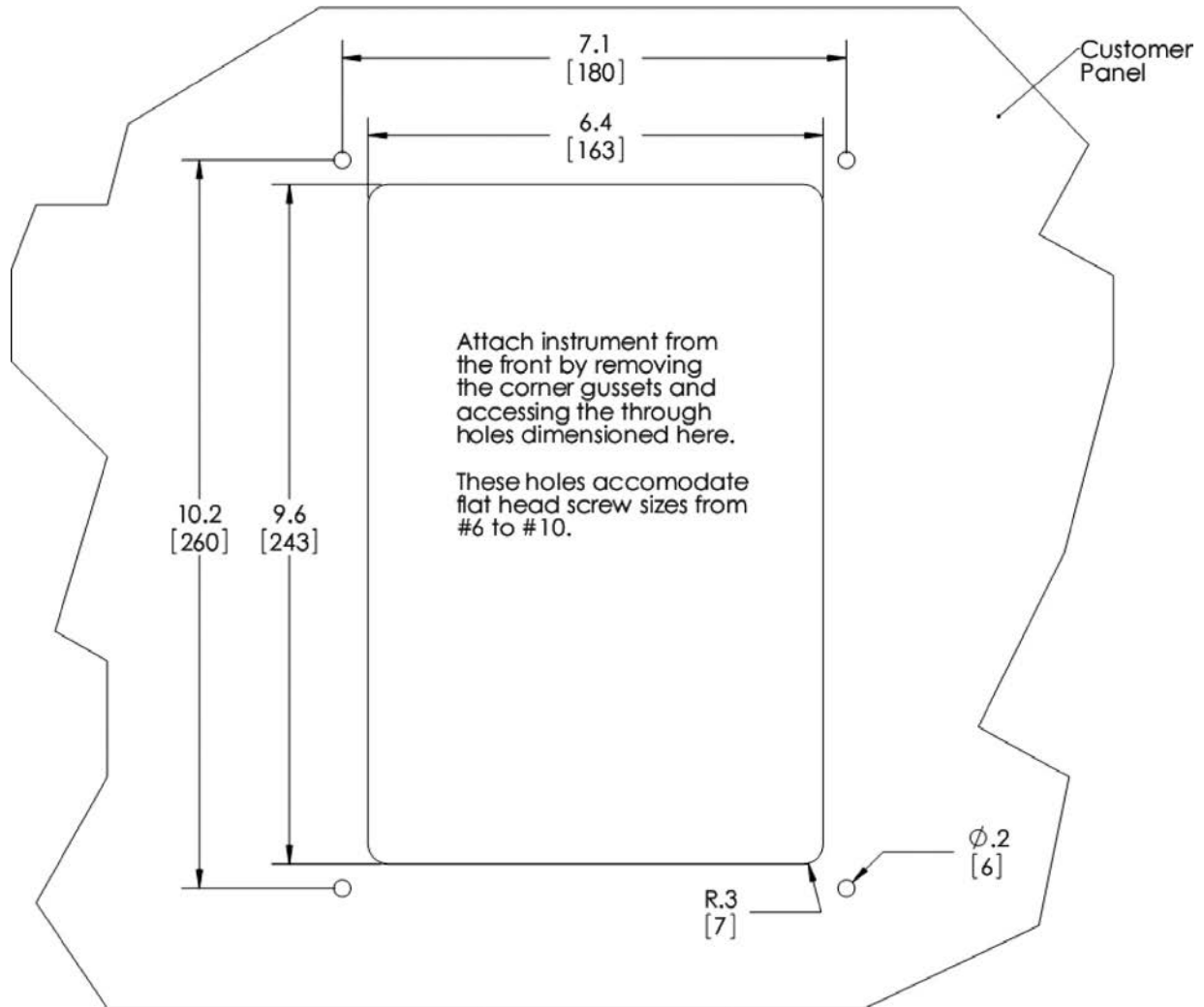

**APPENDIX C**  
**REMOTE SENSOR CONFIGURATION**  
**PART NUMBERS BTR, & PNR**

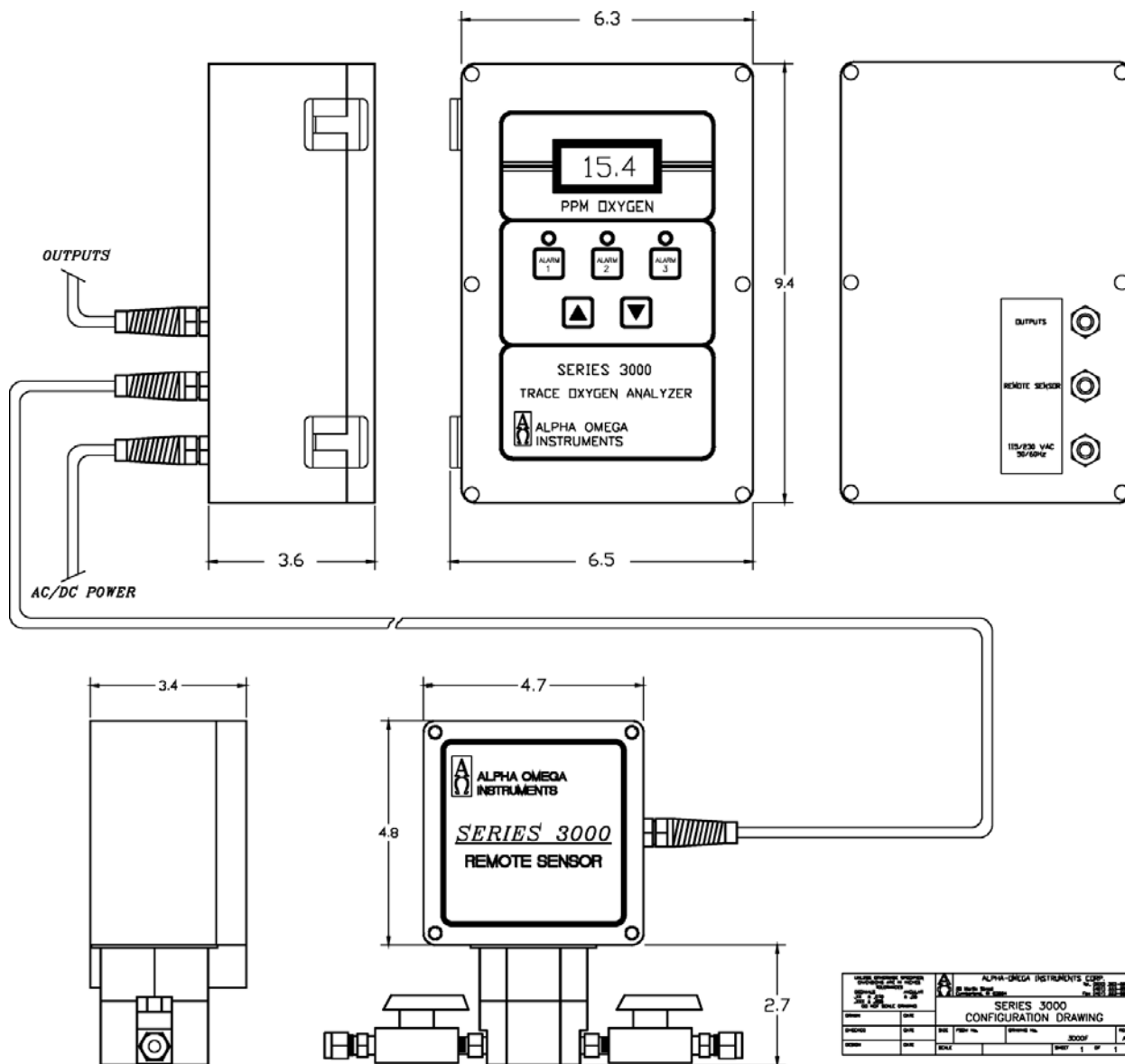

**APPENDIX D**  
**EXPLOSION PROOF ELECTRONICS/SENSOR**  
**CONFIGURATION**  
**PART NUMBER EXX**  
**FRONT VIEW**

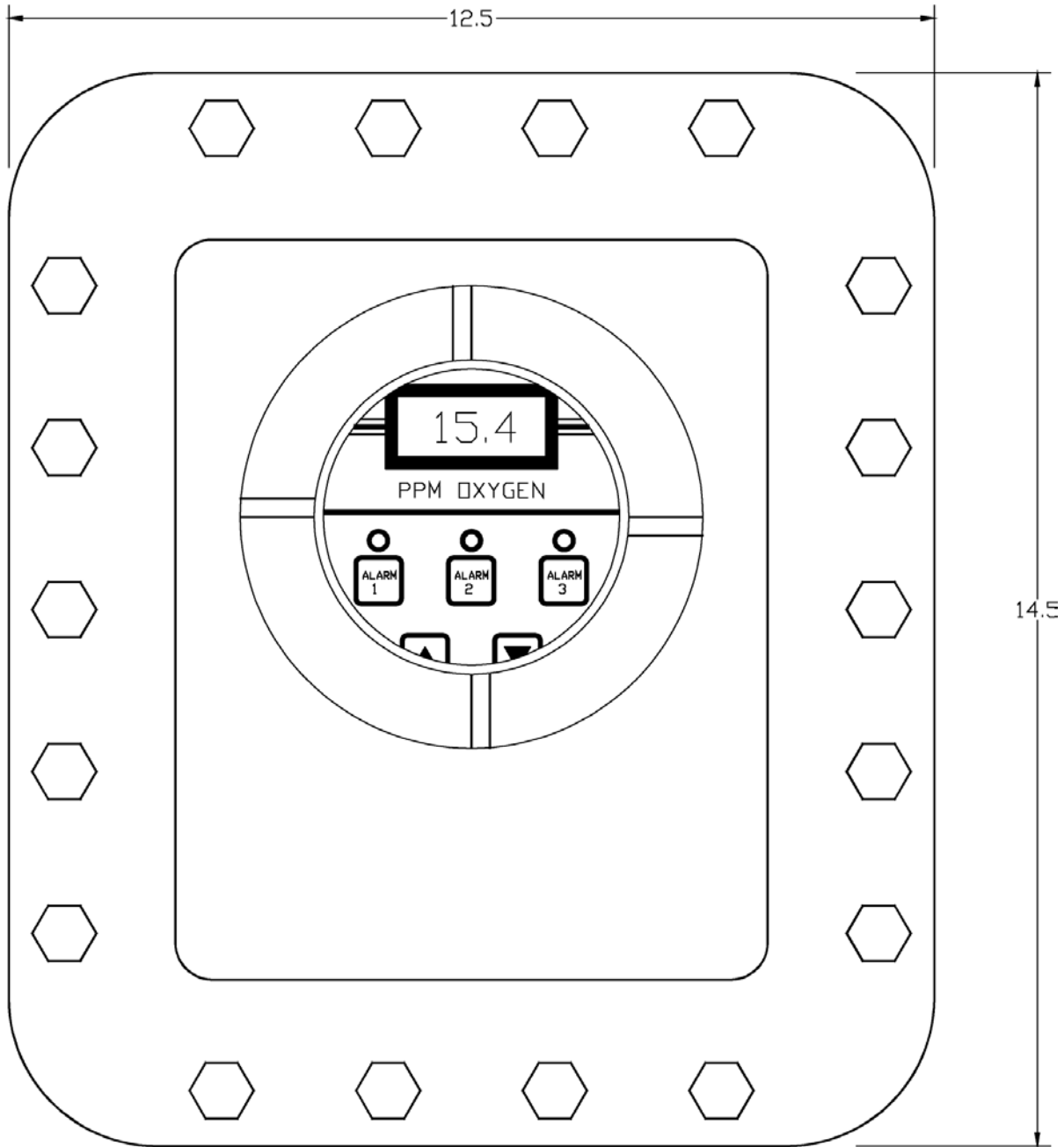

UNLESS OTHERWISE SPECIFIED: DIMENSIONS ARE IN INCHES		ALPHA-OMEGA INSTRUMENTS CORP.	
DECIMALS TOLERANCES		30 North Street Cumberland, RI 02864	
ANGULAR ± .05		Tel. (401) 382-8877 Fax (401) 333-8880	
DO NOT SCALE DRAWING		Fax (401) 333-8660	
DRAWN	DATE	SERIES 3000 CONFIGURATION DRAWING	
CHECKED	DATE	SIZE	REV. A
DESIGN	DATE	SCALE	3000H
		SHEET 1 OF 1	

**APPENDIX D (continued)**  
**EXPLOSION PROOF ELECTRONICS/SENSOR**  
**CONFIGURATION**  
**PART NUMBER EXX**  
**SIDE VIEW-ELECTRICAL CONNECTIONS**

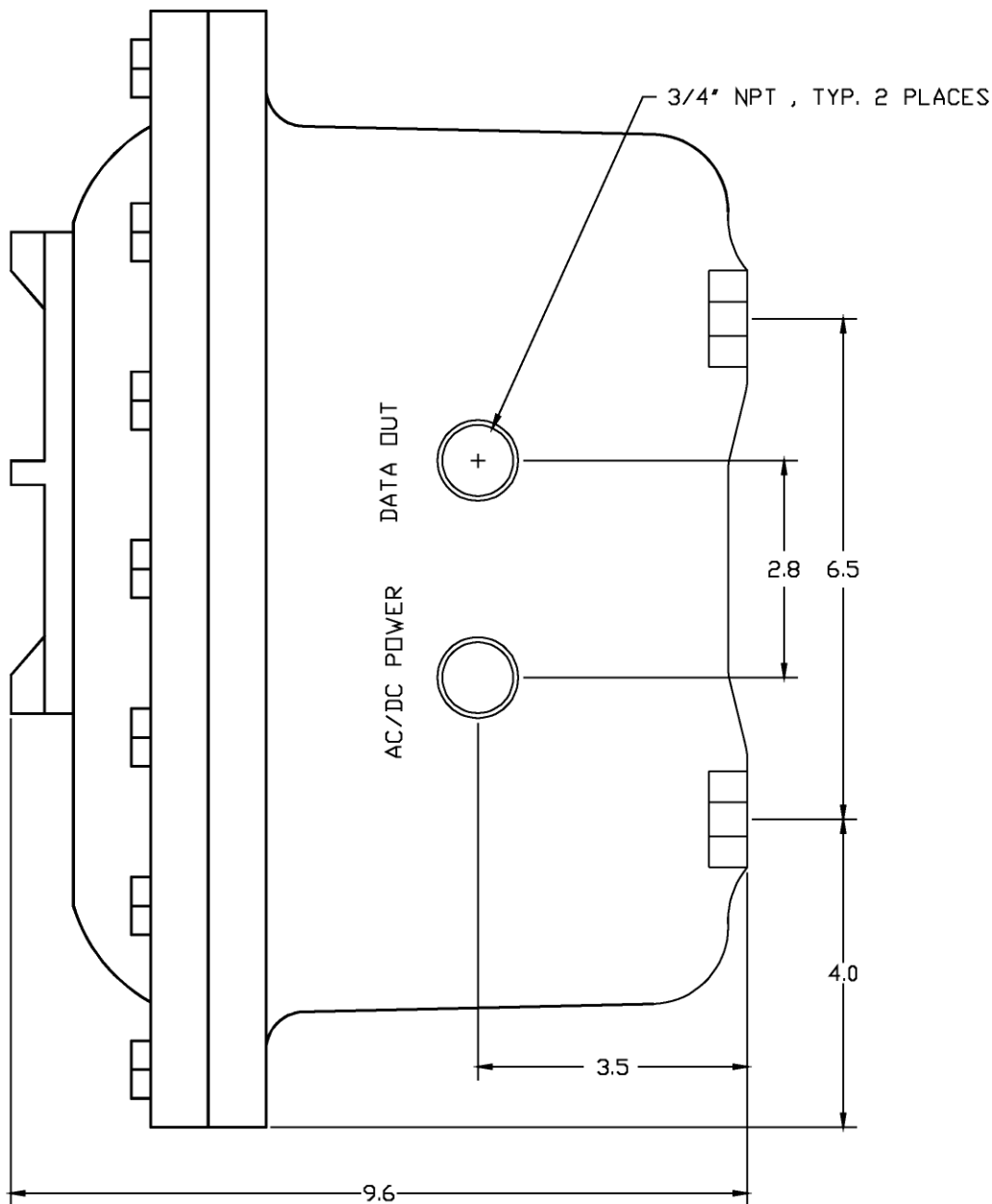

UNLESS OTHERWISE SPECIFIED DIMENSIONS ARE IN INCHES		ALPHA-OMEGA INSTRUMENTS CORP. 20 North Street Canaan, Ct 06026			
DECIMALS 2	ANGULAR 2 .05	Tel: (203) 262-9477 Fax: (203) 535-8580		Tel: (203) 535-8580 Fax: (203) 535-3282	
SERIES 3000 CONFIGURATION DRAWING					
DRAWN	DATE	SIZE	FSCH. NO.	DRAWING NO.	REV.
CHECKED	DATE			3000I	A
DESIGN	DATE	SCALE		SHEET 1 OF 1	

APPENDIX D (continued)  
 EXPLOSION PROOF ELECTRONICS/SENSOR  
 CONFIGURATION PART PART NUMBER EXX  
 SIDE VIEW-GAS CONNECTIONS

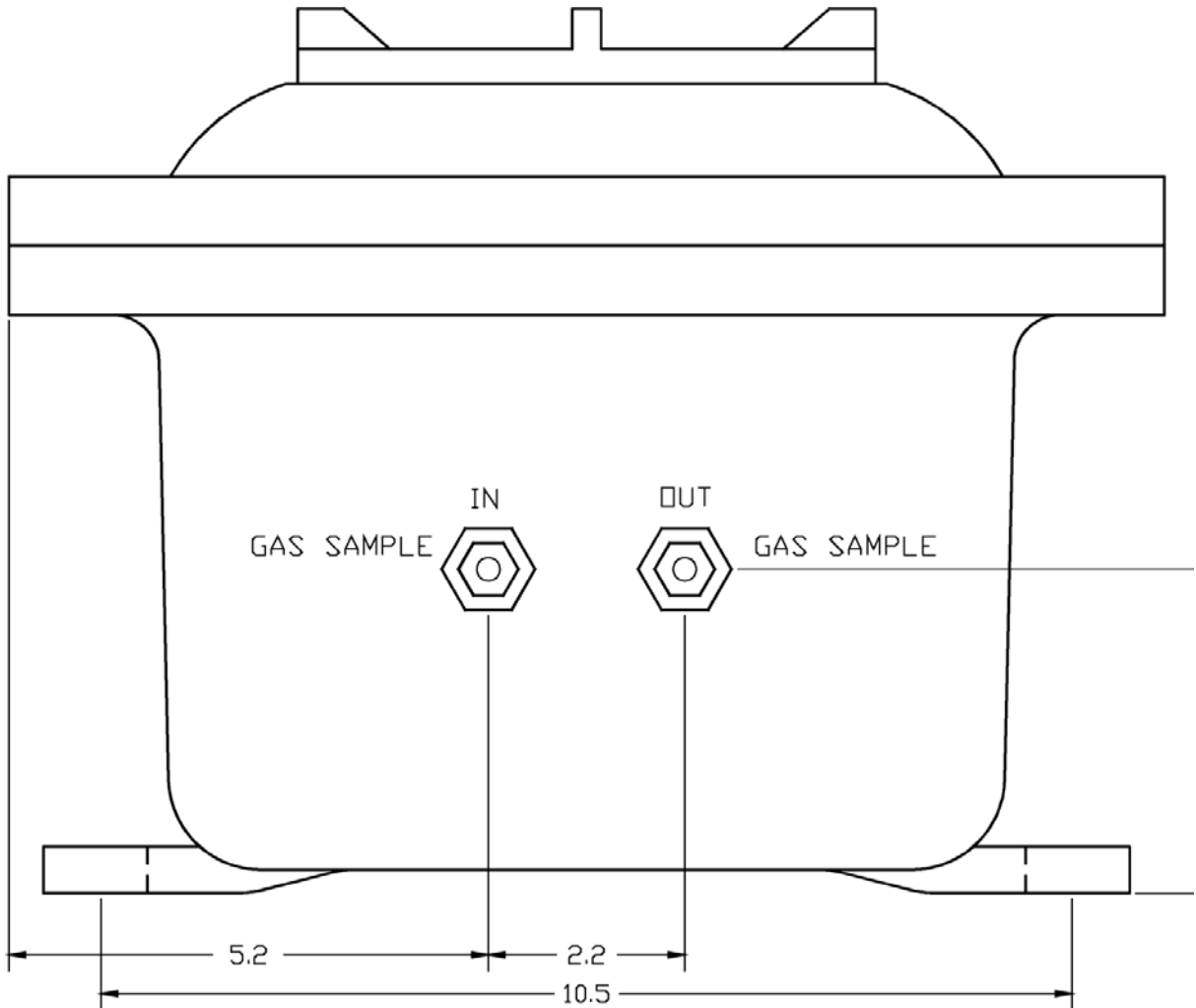

UNLESS OTHERWISE SPECIFIED: DIMENSIONS ARE IN INCHES TOLERANCES		ALPHA-OMEGA INSTRUMENTS CORP. 30 Martin Street Cumberland, RI 02854				Tel. (800) 282-5877 (401) 333-8000 Fax (401) 333-6550	
DECIMALS XX ± .010 XXX ± .005 DO NOT SCALE DRAWING	ANGULAR ± .05	SERIES 3000 CONFIGURATION DRAWING					
DRAWN	DATE	SIZE	FSCM No.	DRAWING No.	3000J	REV.	A
CHECKED	DATE	SCALE			SHEET 1 OF 1		
DESIGN	DATE						



**APPENDIX E**  
**EXPLOSION PROOF SENSOR**  
**CONFIGURATION PART NUMBER**  
**BTX & PTX**

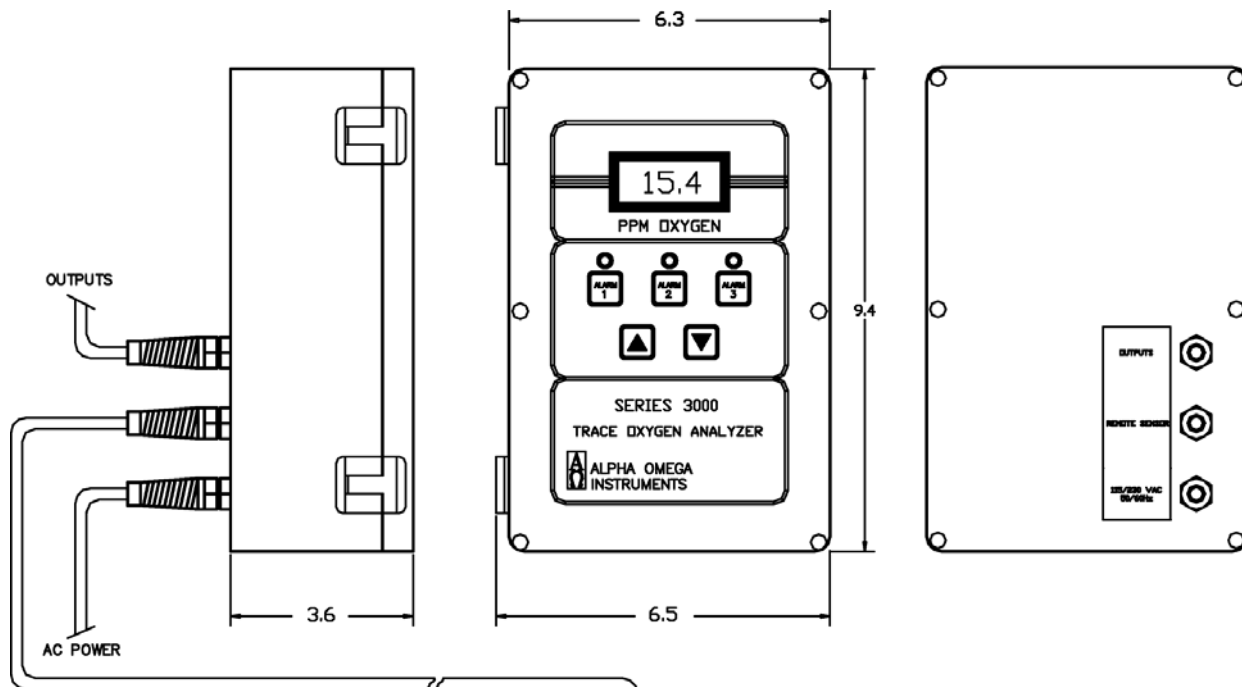

UNLESS OTHERWISE SPECIFIED DIMENSIONS ARE IN INCHES TOLERANCES		ALPHA-OMEGA INSTRUMENTS CORP. 30 North Street Cranford, NJ 07096		Tel: (908) 333-5877 Fax: (908) 333-5888	
DECIMALS 1/16 & 3/16 1/32 & 1/64 DO NOT SCALE DRAWING		<b>SERIES 3000 XR CONFIGURATION DRAWING</b>			
DRAWN	DATE	SIZE	FORM No.	DRAWING No.	REV.
S.B.H.	06/02/98			S3000XR	A
CHECKED	DATE	SCALE			SHEET 1 OF 1

SEE DRAWING XJIHS5MS FOR SENSOR HOUSING  
 DIMENSIONAL DETAILS

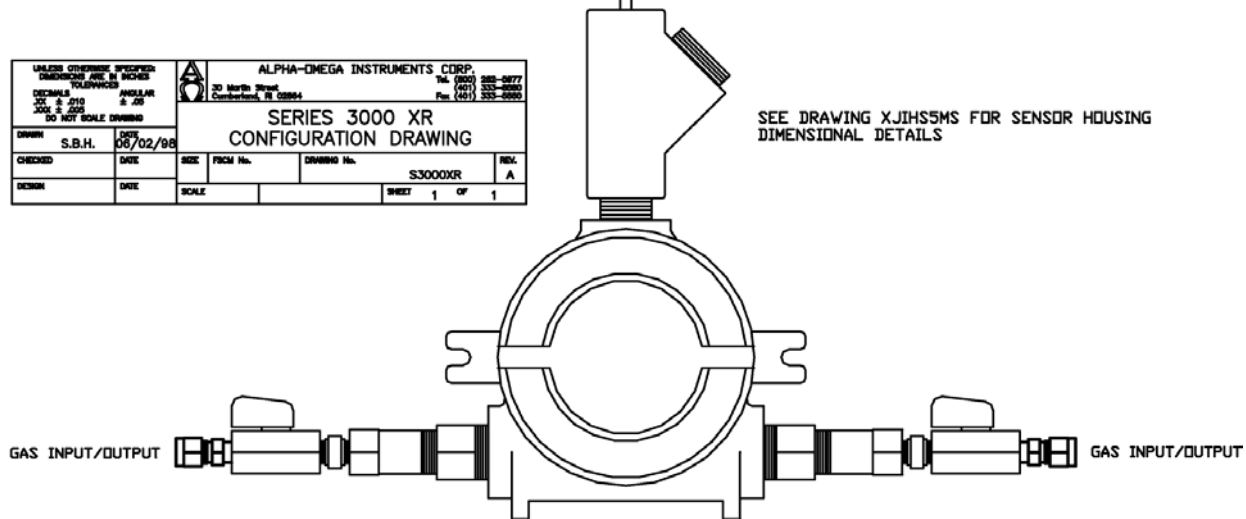

**APPENDIX E (continued)**  
**EXPLOSION PROOF SENSOR**  
**HOUSING USED WITH THE**  
**BTX & PTX CONFIGURATIONS**

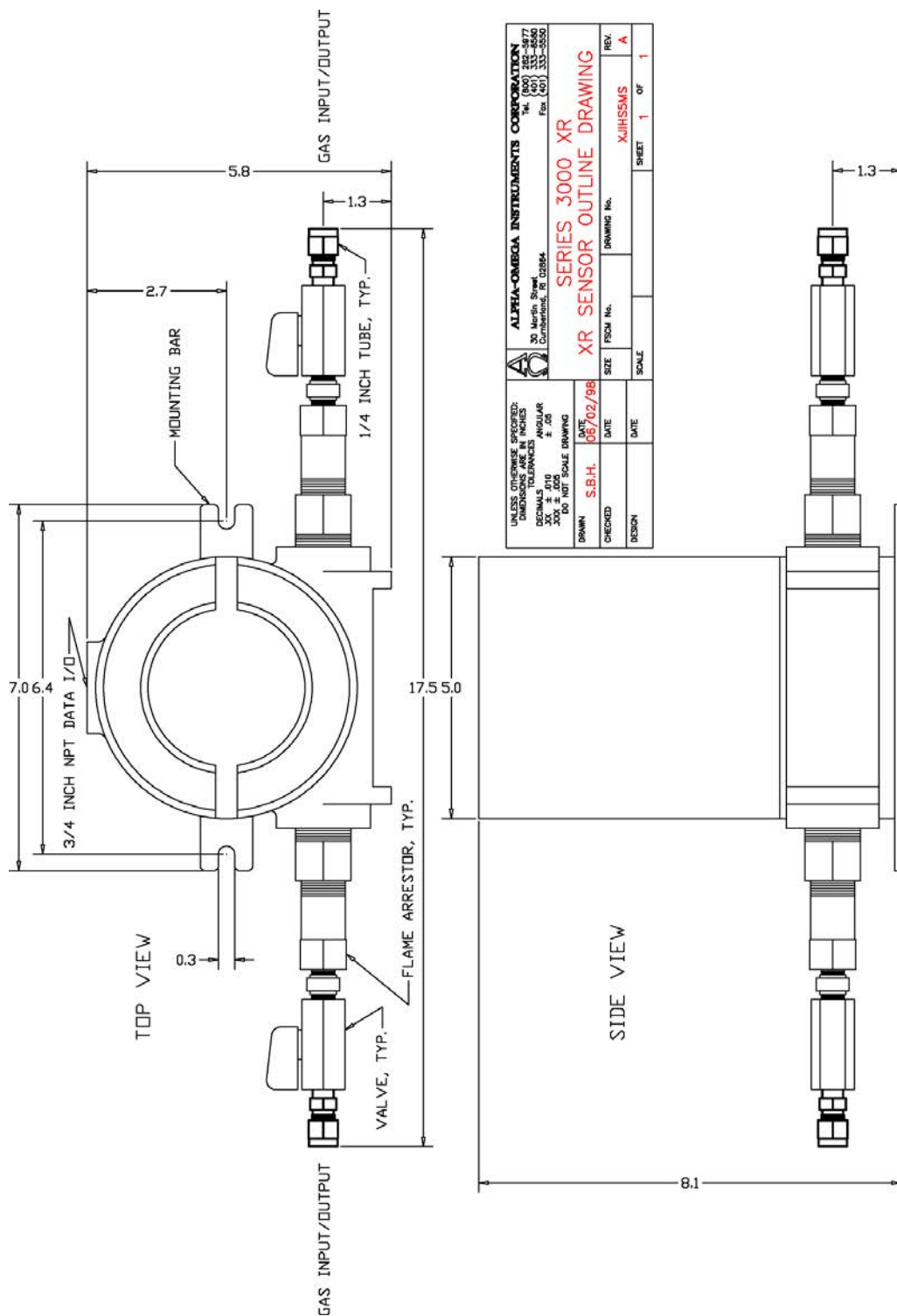

UNLESS OTHERWISE SPECIFIED: DIMENSIONS ARE IN INCHES DECIMALS - TOLERANCES ANGULAR .XX ± .010 .XXX ± .005 .00 NOT SCALE DRAWING		ALPHA-OMEGA INSTRUMENTS CORPORATION No. 30 Martin Street Cumberland, R. 02854 Tel. (603) 333-8560 Fax (603) 333-5555	
DRAWN S.B.H.	DATE 08/02/98	SIZE A	DRAWING No. XJHSSMS
CHECKED S.B.H.	DATE 08/02/98	SCALE 1 OF 1	REV. A
DESIGN S.B.H.	DATE 08/02/98	SHEET 1 OF 1	TITLE XR SENSOR OUTLINE DRAWING

**APPENDIX F**

**MSDS Sheet for the 3SEN Oxygen Sensor**

**10.1 Product Identification**

Product Name	Oxygen Sensor Model Prefix 3SEN
Synonyms	Electrochemical Sensor, Galvanic Fuel Cell
Manufacturer	Alpha Omega Instruments Corp.
Emergency Phone Number	401.333.8580
Preparation / Revision Date	January 1, 1995
Notes	) <i>Oxygen sensors are sealed, contain protective coverings and in normal conditions do not present a health hazard.</i>  ) <i>Information applies to electrolyte unless otherwise noted.</i>

**10.2 Specific Generic Ingredients**

Carcinogens at levels > 0.1%	None
Others at levels > 1.0%	Potassium Hydroxide, Lead
CAS Number	Potassium Hydroxide = KOH 1310-58-3, Lead = Pb 7439-92-1
Chemical (Synonym) and Family	Potassium Hydroxide (KOH) – Base, Lead (Pb) – Metal

**10.3 General Requirements**

Use	Potassium Hydroxide - electrolyte, Lead - anode
Handling	Rubber or latex gloves, safety glasses
Storage	Indefinitely

**10.4 Physical Properties**

Boiling Point Range	100 to 115° C
Melting Point Range	KOH -10 to 0° C, Lead 327° C
Freezing Point	-40 to 0° C
Molecular Weight	KOH = 56, Lead = 207
Specific Gravity	1.09 @ 20° C
Vapor Pressure	Not applicable
Vapor Density	Not applicable
pH	> 14
Solubility in H <sub>2</sub> O	Complete
% Volatiles by Volume	None
Evaporation Rate	Similar to water
Appearance and Odor	Colorless, odorless aqueous solution

**APPENDIX F (continued)**

**10.5 Fire and Explosion Data**

Flash and Fire Points	Not applicable
Flammable Limits	Not flammable
Extinguishing Method	Not applicable
Special Fire Fighting Procedures	Not applicable
Unusual Fire and Explosion Hazards	Not applicable

**10.6 Reactivity Data**

Stability	Stable
Conditions Contributing to Instability	None
Incompatibility	Avoid contact with strong acids
Hazardous Decomposition Products	None
Conditions to Avoid	None

**10.7 Spill or Leak**

Steps if material is released	)	Sensor is packaged in a sealed plastic bag, check the sensor inside for electrolyte leakage.
	)	If the sensor leaks inside the plastic bag or inside an analyzer sensor housing do not remove it without rubber or latex gloves and safety glasses and a source of water.
		Flush or wipe all surfaces repeatedly with water or wet paper towel (fresh each time).
Waste Disposal Method		In accordance with federal, state and local regulations

**10.8 Health Hazard Information**

Primary Route(s) of Entry	Ingestion, eye and skin contact
Exposure Limits	Potassium Hydroxide - ACGIH TLV 2 mg/cubic meter; Lead - OSHA PEL .05 mg/cubic meter
Ingestion	Electrolyte could be harmful or fatal if swallowed. Oral LD50 (RAT) = 2433 mg/kg
Eye	Electrolyte is corrosive and eye contact could result in permanent loss of vision.
Skin	Electrolyte is corrosive and skin contact could result in a chemical burn.
Inhalation	Liquid inhalation is unlikely.
Symptoms	) Eye contact - burning sensation. Skin contact - soapy slick feeling.
Medical Conditions Aggravated	None
Carcinogenic Reference Data	) NTP Annual Report on Carcinogens - not listed ) LARC Monographs - not listed OSHA - not listed
Other	Lead is listed by some states as a chemical known to cause birth defects or other reproductive harm.

ADDENDUM 1

Sensor Auto-Isolation Feature (P/N 3SOL-Auto)

**If the analyzer in question has been equipped with the aforementioned option, please review the following information before operating the analyzer.**

The Series 3000 Trace Oxygen Analyzer features a "Advanced Long-Life" Electrochemical Sensor. Like all electrochemical trace oxygen sensors, exposure to high oxygen concentrations, such as that contained in air (209,000 PPM), must be avoided to help preserve the longevity of the sensor. To minimize exposing the Series 3000 to excessive levels of oxygen (excessive levels are concentrations beyond the highest range of the analyzer), Alpha Omega Instruments offers an optional **Sensor Auto-Isolation** feature.

Sensor Auto-Isolation provides improved recovery time when the instrument is exposed to "excessive" levels of oxygen. This is accomplished by using the analyzer's third oxygen alarm (Alarm 3) set point and relay output in conjunction with a pair of electrically actuated solenoid valves. The valves have been installed on the sample gas inlet and outlet ports of the sensor housing and with no power applied are closed. Alarm 3 has been preset at the factory to trip at an oxygen concentration equivalent to 20% of the analyzer's highest range. For example, if the analyzer in question has three ranges such as 0-100/1,000/10,000, Alarm 3 will be set to close the solenoids at an oxygen concentration equivalent of 2,000 PPM (20% of 10,000 PPM).

During normal operation, if the oxygen concentration exceeds the 20% value the solenoid valves will close, isolating the sensor and preventing flow of sample gas. The power to the solenoids are wired to the NC contacts of the relay associated with Oxygen Alarm 3. This relay has been configured to latch so the relay contacts will remain in the "tripped" state preventing power to the solenoid valves until the alarm condition has been manually cleared. When the alarm condition is manually cleared using the front panel button "Alarm 3", power is applied to the valves allowing sample flow through the sensor housing. When clearing of the alarm is desired depress the Alarm 3 button three times to clear the alarm condition. Pressing the button once silences the alarm, twice enters alarm setup mode, and three times establishes normal operation.

If the oxygen concentration should rise above the set point after the alarm has been cleared, in all likelihood the system needs to be purged with an inert gas (i.e. nitrogen, argon, etc.). In this scenario, the valve positions must be forced open to allow passage of inert gas. To accomplish this, an override switch has been installed on the right side of the analyzer labeled "Auto-Isolation Override". The switch is a momentary type (needs to be manually held) to maintain the open position of the valves. While holding the switch down, ensure there is a flow of sample gas and wait until the front panel meter indicates an acceptable concentration of oxygen (below the 20% level described above). Once accomplished, release the switch and proceed clearing the alarm as described in the previous paragraph.

ADDENDUM 1 (continued)

Sensor Auto-Isolation Feature (P/N 3SOL-Auto)

# 3-SOL-AUTO

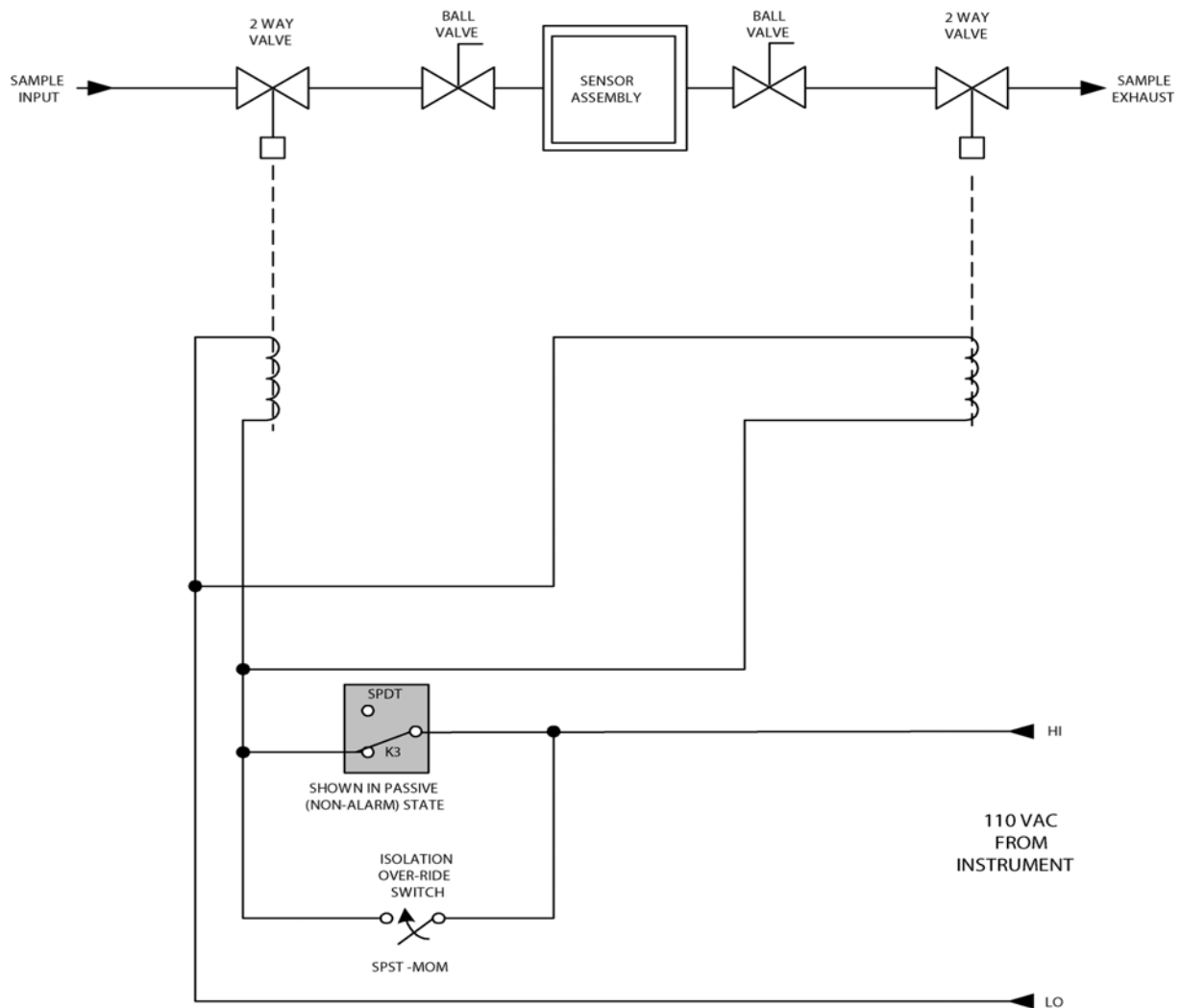

ADDENDUM 2

**AC-Actuated 3-way Solenoid Valve (P/N 3-3waySOL-115) and  
Sensor AutoPurge Protection (P/N 3-AutoPurge)**

**If the analyzer in question has been equipped with the two aforementioned options, please review the following information before operating the analyzer.**

The AC-actuated 3-way Solenoid Valve has been installed on the sample gas inlet line and is used to select between an inert gas purge (i.e. nitrogen, argon, helium, etc.) and the sample gas source. The optional Sensor Auto-Purge Protection feature provides the added capability of protecting the oxygen sensor in the event high oxygen concentrations are introduced into the sample gas. In addition to protecting the oxygen sensor from potential damage, these two features, when working in tandem, enhance system recovery time should such a disruption take place.

Under normal operation, the control logic of the Series 3000 directs the three way solenoid to provide a flow of sample gas by energizing the solenoid valve. When equipped with the Sensor Auto-Purge Protection feature, the control logic is configured to detect oxygen levels above a preset limit and will automatically select the purge gas line located at the top of the solenoid valve if this limit has been exceeded.

When the Auto-Purge Protection feature has been supplied, Oxygen Alarm 3 is configured at the factory to trip at 20% (user adjustable) of full scale on the analyzer's highest range, and configured as a high alarm (trip upon increasing O<sub>2</sub>). This alarm can be configured as a latching alarm or as non-latching.

When configured as a latching alarm, the alarm will remain in the tripped state until manually acknowledged on the front panel, even if the O<sub>2</sub> level drops back below the trip point. To acknowledge the alarm, depress the Alarm 3 button three times to CLEAR the alarm without adjusting the level. If the incoming sample O<sub>2</sub> level is still above the Alarm #3 trip-point, then the conditions causing the instrument to switch to purge in the first place will repeat. Leave the instrument operating on the purge gas and investigate the reason for the over-range sample condition.

When the alarm is configured as non-latching, the alarm will automatically reset when the oxygen level drops below the alarm level. This will automatically select the sample input once again. If the O<sub>2</sub> level rises and remains above the Alarm #3 trip-point for more than 1 minute, then the alarm should be set for latching behavior; this will allow the user to troubleshoot the nature of the sample gas problem. The first potential problem to investigate is leakage of excessive levels of oxygen in the sample gas lines.

Once the abnormally high O<sub>2</sub> sample condition is rectified, toggle the "Auto-Purge Override" switch on right of the side of the analyzer, holding it down. Depressing the switch will allow sample gas to flow through the sensor. If the O<sub>2</sub> level rises and remains above the Alarm #3 trip-point for more than 1 minute, then release the switch, allowing the instrument to return to purge and again investigate the source of the excess oxygen in the sample line.

Note that setup of either "Auto-Clear" or "Manual Clear" for Alarm #3 affects the operation of ALL alarms, in particular the **two** remaining oxygen alarm relays as they will all behave in the same way. Please also note that Instruments equipped with the Sensor AutoPurge Protection option have only (2) oxygen alarms remaining for customer use. **CAUTION:** When ENERGIZED, The Solenoid Valve Body can be **HOT!**

ADDENDUM 2 (continued)

**AC-Actuated 3-way Solenoid Valve (P/N 3-3waySOL-115) and  
 Sensor AutoPurge Protection (P/N 3-AutoPurge)**

3-3WaySOL-115 & 3-AutoPurge

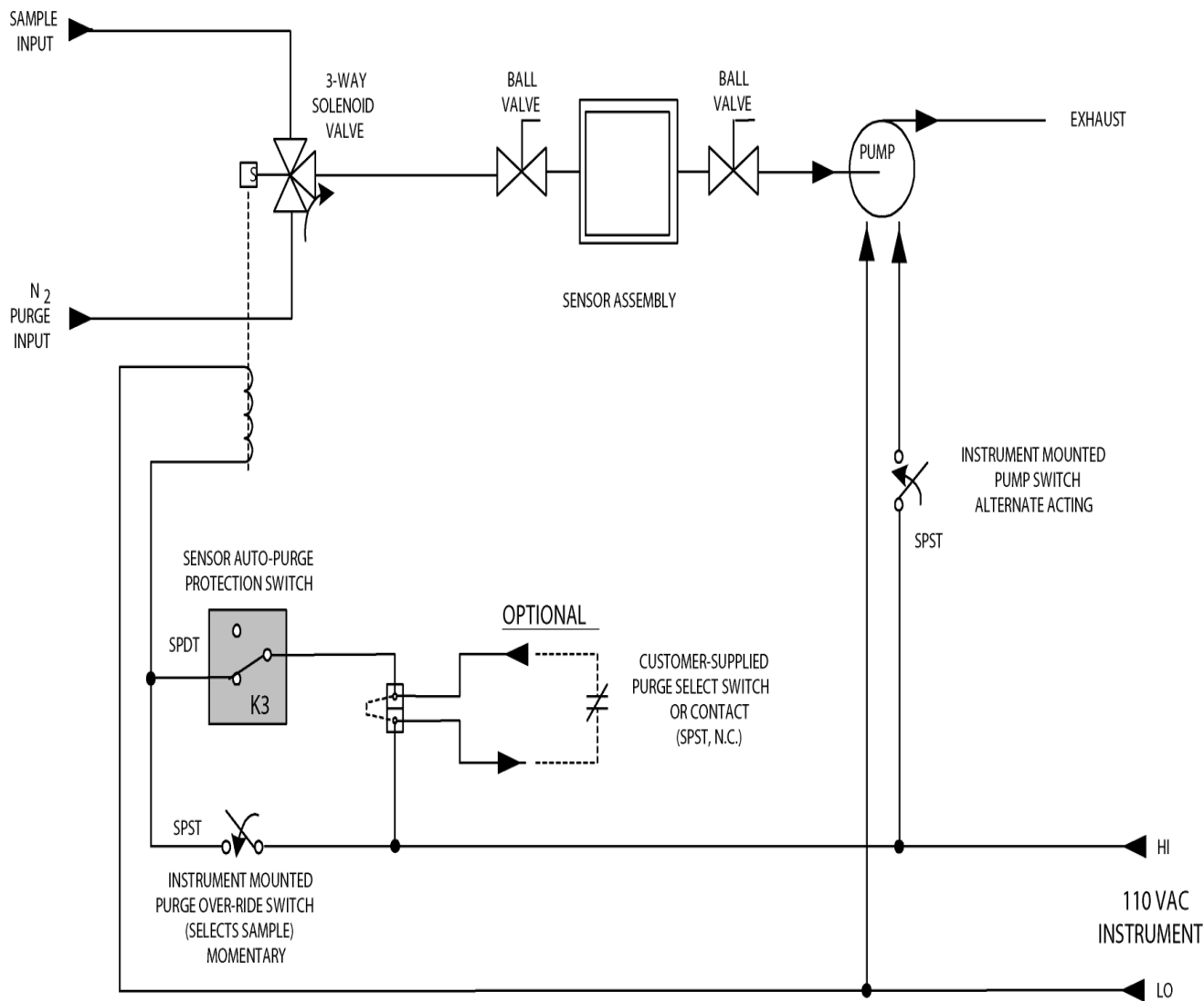



ADDENDUM 3

Sample Line Block & Bleed  
Sensor-Isolation Sample Gas Delivery System (P/N 3ISO-BB)

Recommended for "portable/trans-portable" Trace O<sub>2</sub> Analysis applications  
Spot or Intermittent Trace O<sub>2</sub> Readings at Different Sample Tap Locations

If your analyzer has been equipped with the above option, please read below.

The "Sample Line Block & Bleed / Sensor-Isolation Gas Delivery System" option serves as a convenient means to "PURGE" (or "BLEED") the sample line before switching the sensor over to the "SAMPLE" position, yet simultaneously keeping the sensor in an "Isolated" state (with a pre-purged, low-O<sub>2</sub> background gas atmosphere sealed inside). Upon relocation and connection to subsequent gas samples, the Alpha Omega Instruments Trace Oxygen Analyzer is, therefore, *primed-and-ready-to-go* to make a trace O<sub>2</sub> reading, because:

1. The O<sub>2</sub> sensor is already reading and equilibrated on a low O<sub>2</sub> sample, immediately prior to switching over to the next gas sample.
2. At the same time, immediately prior to being switched over to the next sample, also, the sample line is completely "pre-purged" by the next gas sample (purging out all of the previous gas sample, and (or) any possibility of entrained air.

The "Sample Line Block & Bleed / Sensor-Isolation Gas Delivery System" option utilizes the analyzer's own sample conditioning components [i.e., pump, regulator, flowmeter, filter(s), etc.] to perform the "PURGE" (bleed) operation.

Regardless of whether each gas sample is under pressure (with flow controlled by a regulator or needle valve) or under vacuum conditions (aspirated by a sample pump or other means), Used as a flow pre-set adjustment, and because the pressure differential across the sensor is negligible,

**CAUTION: IT IS ESSENTIAL FOR THE SENSOR'S LONGEVITY AND PERFORMANCE BELOW 100 PPM THAT THE RETAINED GAS INSIDE THE SENSOR HOUSING AFTER ISOLATION IS AT A LOW TRACE O<sub>2</sub> LEVEL ( Below the highest range of the instrument ).**

**ADDENDUM 3 (continued)**  
**OPERATION**

1. Ensure that the Analyzer is ON, and that the “Block & Bleed / Sensor Isolation 4-way Sample Selector Valve” is pointing toward the “BLEED / BYPASS” label (or toward the port connected to the base of the flowmeter).
2. Connect the Sample Gas to the ¼” compression Sample Inlet Fitting on “Block & Bleed / Sensor Isolation 4-way Sample Selector Valve.” (Note: this is the only unused port connection).
3. Using available sample pump, regulator, or other flow controls, establish the suggested 0.5 slpm (0.2 to 1.2 slpm) sample flow.

Note: While in the “BLEED / BYPASS” position, the sample gas is re-directed from the sample inlet to the outlet, “bypassing” the sensor. Bleed the sample line for a few seconds to a few minutes (depending upon sample line length, any filter bowls or other “dead volumes”, etc.).

4. Switch the “Block & Bleed / Sensor Isolation Four-Way sample Selector Valve” to the “MEASURE” position (pointing toward the sensor housing). Verify that the flow rate remains the same.
5. After allowing enough time on the sample for a sufficiently stable O<sub>2</sub> reading, switch back to the “BLEED/BYPASS” position.

**Note:** **ENSURE** that the O<sub>2</sub> reading while in the “BLEED / BYPASS” position (Bypass & Bleed Sensor Isolation) state is:

**BELOW 1,000ppm.**

Otherwise, purge the sensor out IMMEDIATELY using a better purity purge gas.

ADDENDUM 3 (continued)

**Sample Line Block & Bleed / Sensor-Isolation  
Sample Gas Delivery System**

**P/N 3ISO-BB**

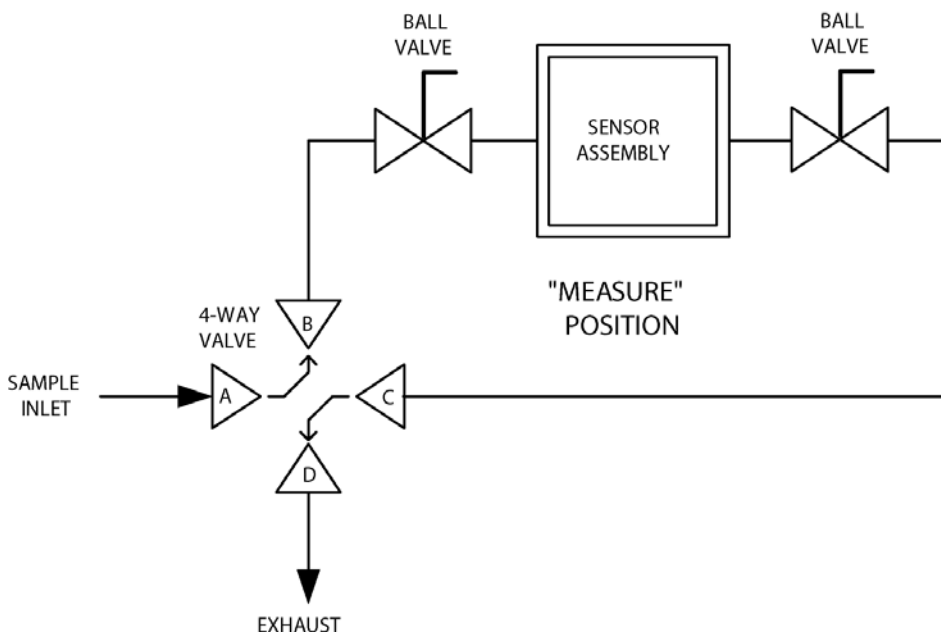
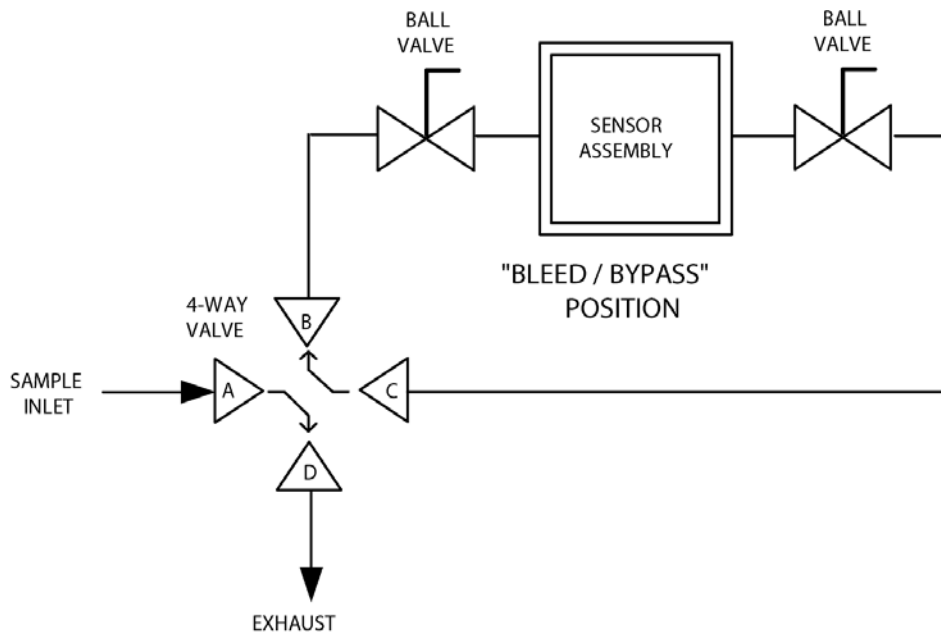

ADDENDUM 4

Optional Internal Data Logger (P/N 3DL)

If your analyzer has been equipped with the above option, please read below.

**Note: The standard 0-2V DC output associated with the Series 3000 is used as the input to the data logger. As a result, this 0-2V DC output is not available for any other use.**

Alpha Omega Instrument's optional internal data logger provides four channels with a data storage capacity of 43,000 data readings with a user-selectable data capture rate.

The factory default for the Series 3000 is single channel operation. As such, the data logger provides up to 43,000 data readings for the single channel (oxygen).

Two cables connect the Data Logger to the instrument:

- 1 The first connection is the 0-2V DC oxygen output of the instrument which connects to Input **Channel 1** of the Data Logger (internal).
- 2 The second connection extends the computer connection of the data logger to the outside of the instrument so that the Data Logger can be launched and data retrieved without opening the instrument's cover (external). This is a USB Mini-B style connector.

Please review the following sections carefully as they contain important operational information. Also, please read the data logger software manual on the compact disc provided with the instrument.

The data logger is usually installed in the instrument's enclosure. However, there are instances when due to either space constraints or a specific customer request, the data logger may be mounted on the outside surface or installed remotely.

***Data Logger Maintenance***

The data logger contains a CR2032 battery that is available from most stores that sell replacement batteries. Replacing the battery should be performed once every 12 months regardless of how often the data logger is used.

**WARNING! UNPLUG POWER CORD FROM AC OUTLET BEFORE ATTEMPTING TO REPLACE THE DATA LOGGER BATTERY!**

**Replacing the Data Logger Battery**

- I. To access the data Logger when mounted internally, open the cover of the instrument to access the device.
  - II. To remove the data logger, unplug the two cables from the data logger, and grasp the device firmly and slide to the side to disengage the mounting nuts (the screws on the back of the instrument labeled "LOGGER" may need to be loosened to remove the logger). The Data Logger can then be opened and the coin-shaped battery replaced according to the instructions in the data logger manual.
  - III. When reinstalling the data logger, position the device over the mounting nuts and slide to the side
- Addendum 4 Continued**
- IV. to secure in place. (the screws on the back of the instrument labeled "LOGGER" may need to be tightened to secure the logger)
  - V. Replace the cables - the gray plug is located into the **Data Channel 1** connector and the USB computer interface cable plug is located into the bottom connector.

- VI. Close the instrument's front panel and clear cover

### Data Logger Software

Follow the instructions in the data logger software manual to install the software onto the personal computer that you will use for data launching and retrieval. Install the communications cable from the computer being used (USB A to USB Mini-B) to the analyzer's data logger connector, located either on the rear or side of the instrument.

Before launching the data logger, please review the following information:

- I. Data interval desired between points. This interval can range from 1 second between points to 18 hours between points. Estimate the full capacity time by multiplying the data interval times 43,000.
- II. The data logger needs to be set up to log a **0-2.5V DC** signal on **Channel 1**. If the data logger is not already set up to do so, this can be accessed by pressing the "Launch" button on the toolbar. The options under the "Sensors" section can be used to **disable all channels except Channel 1** and also setup channel 1 for "**Adapter Cable 0-2.5V DC**" input signal.
- III. **Note: Each time the data logger is stopped and re-launched, any previously stored data in the logger will be deleted. Be sure to read out the data from the data logger using the Readout icon on the toolbar before launching the data logger again.**
- IV. Each time the data is retrieved from the data logger, the option is given to stop data acquisition or continue logging, if data acquisition is stopped, the logger must be launched again.
- V. The data stored in the logger is normally a voltage value. The conversion of the 0-2V DC output from the data logger to a specific oxygen concentration is quite simple. To calculate the oxygen concentration from the data logger use the example below. Based on an instrument with a single range of measurement of 0-10ppm oxygen and an output from the data logger of 0.5V DC.

$$\frac{10 \text{ PPM}}{X} = \frac{2 \text{ VDC}}{0.5 \text{ VDC}}$$

$$X = \frac{10 (0.5)}{2} = 2.5 \text{ PPM}$$

- VI. The logger has been setup at the factory to scale the voltage data to the instrument's highest operating range. If the instrument is equipped with multiple ranges, the instrument must be set to a single range instead of auto ranging. If data logging over a different range is required, follow the instructions provided in the data logger software manual for scaling the data for the instrument's range. Be sure to set the instrument's range to match the data logger scaling.

**ADDENDUM 5**

**High Volume Pump (P/N 3PMPH)**

**If your analyzer has been equipped with the above option, please read below.**

If the analyzer had been supplied with a high volume pump, when operating the analyzer from a pressurized gas source, disconnect the pump tubing at the meter, fully open the flow meter valve, and **TURN THE PUMP OFF.**

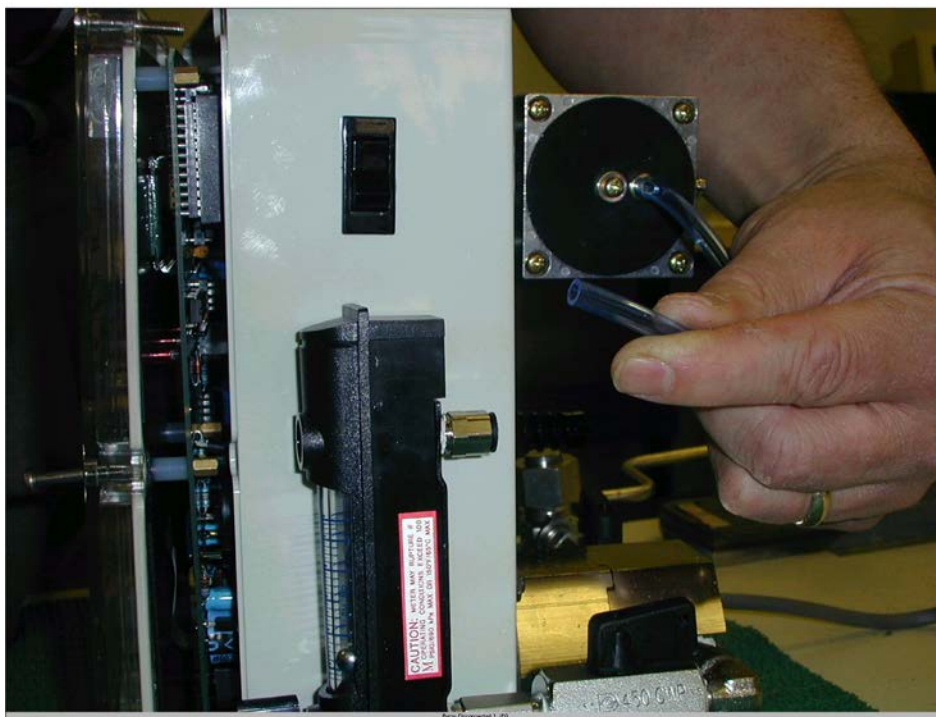
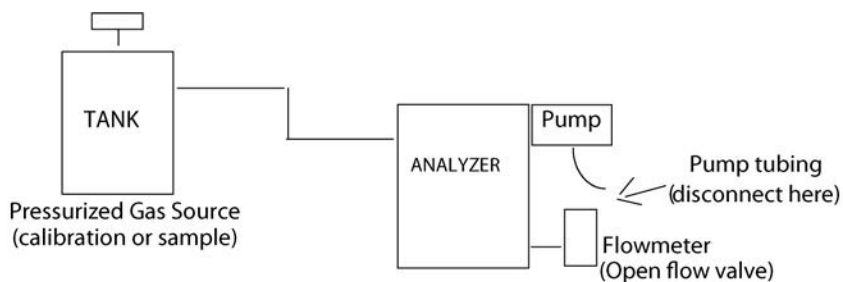

Disconnect tubing at the flow meter

ADDENDUM 6

115 VAC Pump (P/N 3PMP) with Solenoid Valves (115 VAC, 50-60Hz) (P/N 3-SOL-E)

If your analyzer has been equipped with the above option, please read below.

This Series 3000 is equipped with an internal pump and solenoid isolation valves. The valves and pump connections are powered by 115 Volts AC and are connected to two separate rocker switches mounted on the side of the enclosure. There is a terminal block that allows the customer to wire an external switch to either the pump or the solenoids for remotely controlling the power to either one. Please note that the local rocker switches must be ON to enable the external switches. Also, the pump switch requires that the solenoids switch be on first. The terminal block is wired at the factory so that the local switches are enabled. Simply remove the small loop of wire and replace with an appropriately rated remote switch. Any switches used should be rated for at least 15W.

The wiring connections are located on a terminal block which is labeled as follows:

<i>Label</i>	<i>Description</i>
<p style="text-align: center;"><b>“CSP”</b>   <b>Customer Switch – Pump</b></p>	<p>Wiring location for customer provided switch (“CSP”) used to apply the power to the internal <b>PUMP</b>. This can be a contact closure from a switch, relay or PLC. There is a jumper installed at the factory to turn on the pump when 115V volts AC power is applied to the system.</p> <p><b>Note: the pump will NOT turn on unless the switches for the solenoids are turned on first.</b></p>
<p style="text-align: center;"><b>“CSS”</b>   <b>Customer Switch – Solenoids</b></p>	<p>Wiring location for customer provided switch (“CSS”) used to apply power to the internal sensor isolation <b>SOLENOID VALVES</b>. This can be a contact closure from a switch, relay or PLC. There is a jumper installed at the factory to turn on the solenoids when 115V volts AC power is applied to the system. This jumper turns on the solenoids to allow the sample to flow.</p> <p><b>Note: turning the pump on or off requires that the solenoid switches be turned on first.</b></p>

**PLEASE NOTE: THE EXTERNAL WIRING IS 115V AC. PLEASE INSURE THAT THE WIRING IS SAFELY ROUTED TO THE EXTERNAL SWITCH AND LABELED WITH A WARNING OF SHOCK HAZARD IF NECESSARY.**