

PRODUCT BROCHURE

Model LPDT™

Smallest Loop-Powered Aluminum Oxide
Sensor Transmitter Dew Point Transmitter



-100°C TO +20°C Dew Point



Fast

Accurate

Low Maintenance

- Monitoring and control of air dryers
- Plastic dryers
- Glove boxes
- Welding gases
- Clean room environments

The Model LPDT™ is the world's smallest loop-powered (two-wire) dew point transmitter with a display. Model LPDT is a fully functional instrument operated through a miniature custom LCD display and three push buttons, using the same user friendly interface of all hygrometers.

The analog output is linear to the engineering units selected for display and is user configurable.

- Includes fastest aluminum oxide sensor on the market with patented HTF™ (hyper-thin-film) sensor technology
 - Loop-powered transmitter with integrated digital display; also available without display
 - Versatile and compatible with a wide range of gases and fits wide range of applications
-

Features & Benefits

- Display
 - Low maintenance
 - Convenient field exchangeable sensor
 - Robust field programming capabilities
 - Convenient logging feature
 - Adjustable analog outputs
 - Low cost of ownership and maintenance
-

Applications

- Glove boxes
- Natural gas transmission
- Hydrocarbon processing
- Air dryers and compressors
- Specialty air gases
- Cryogenic
- Air generators

Methods of using and Interfacing the LPDT

Operation with Wall Transformer
Dew Point viewed on Instrument Display

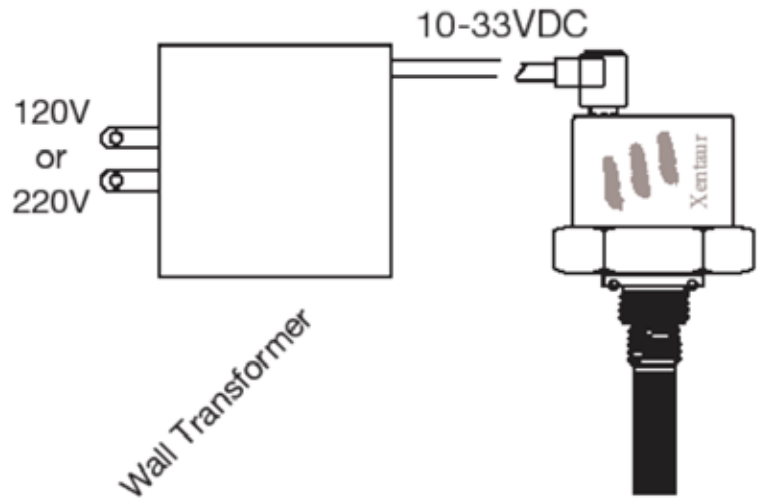

Operation with DC Power Supply
Dew Point viewed on Instrument Display
and available as 4-20mA output

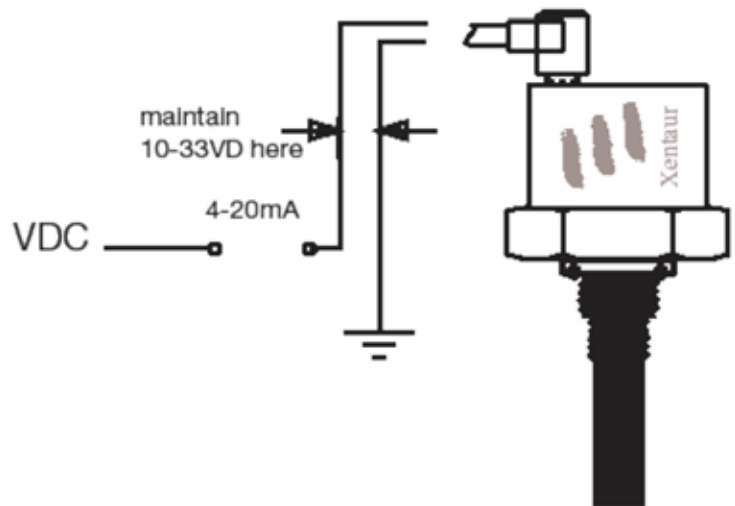

Operation with DC Power Supply
Dew Point viewed on Instrument Display
and available as Voltage output

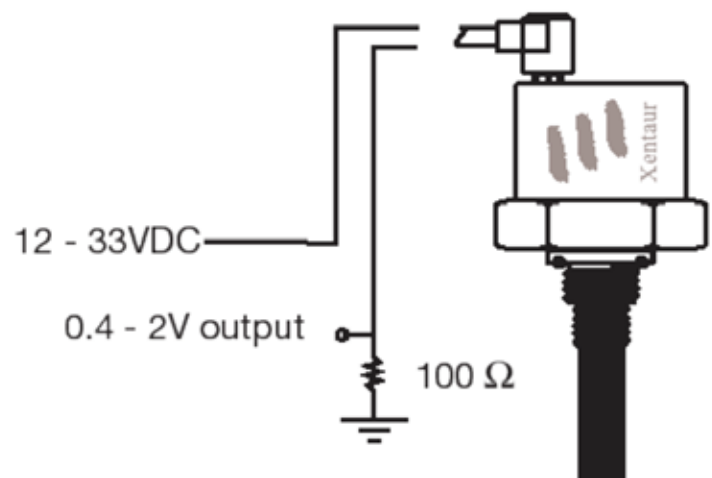

Dimensions

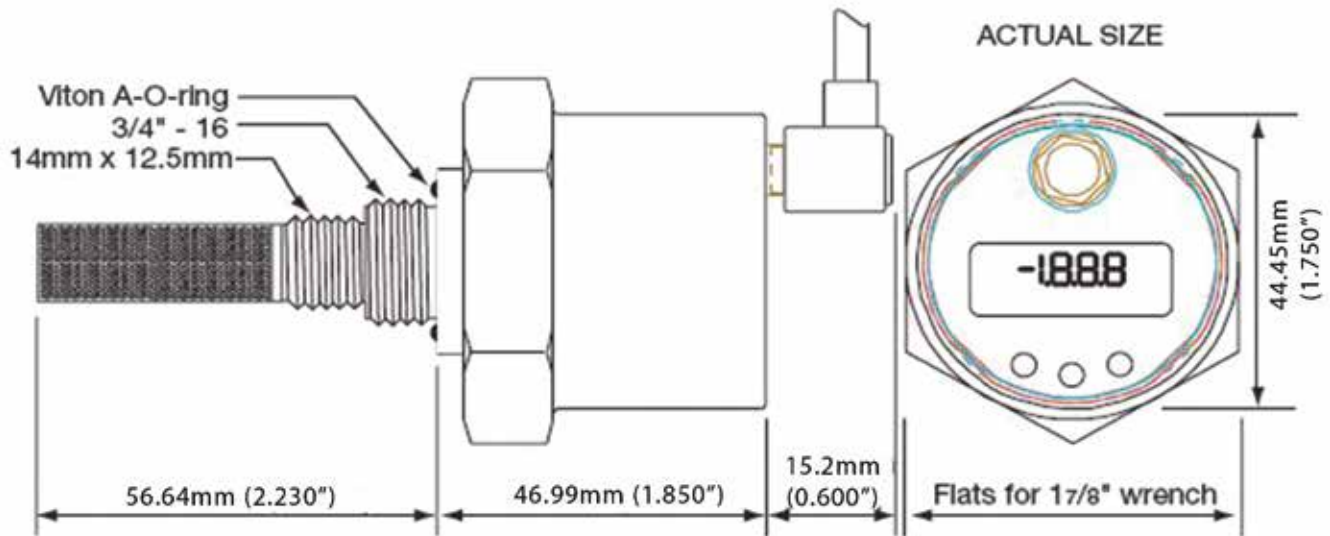

Hyper-Thin-Film (HTF) Al₂O₃ Moisture Sensor Technology

The Model LPDT uses a HTF aluminum oxide sensor. The breakthrough HTF moisture sensor technology represents advances in thin film and metal oxide sciences and offers significant performance advantages over all other aluminum oxide sensors.

The operating principle of the HTF aluminum oxide sensors is that a hygroscopic layer of aluminum oxide adsorbs or releases water molecules within its pores, depending on the water vapor pressure in its environment. The electrical capacitance of the aluminum oxide layer changes with the surrounding water vapor pressure. The electrical capacitance is measured between the aluminum core of the sensor and a porous conductive gold layer on the outside.

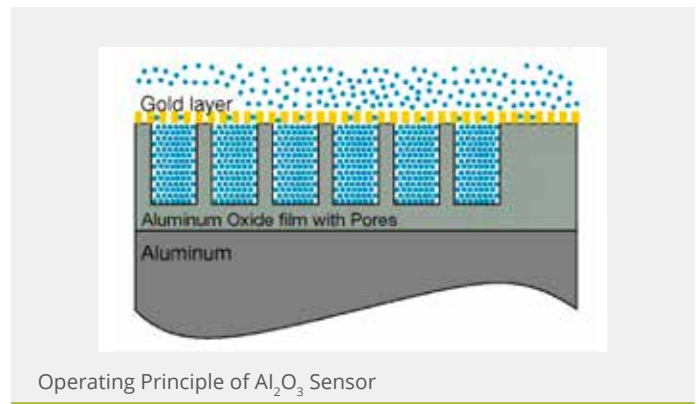

The advantages of the HTF sensor technology are a result of the proprietary manufacturing method in which the aluminum oxide layer is made to be hyper thin as well as extremely hygroscopic. This results in a very sensitive sensor with fast response.

High Capacitance Response

HTF sensors have a capacitance change, several orders of magnitude larger than that of conventional aluminum oxide sensors due to the hyper thin film, a sharp transition layer and a special pore geometry. Additionally, this change is quasi linear and its sensitivity to temperature is negligible. The advantages of a linear high capacitance response are: better sensitivity, better repeatability and faster response times. Also, the measurement system is less prone to noise and drift, and signal conditioning is kept to a minimum.

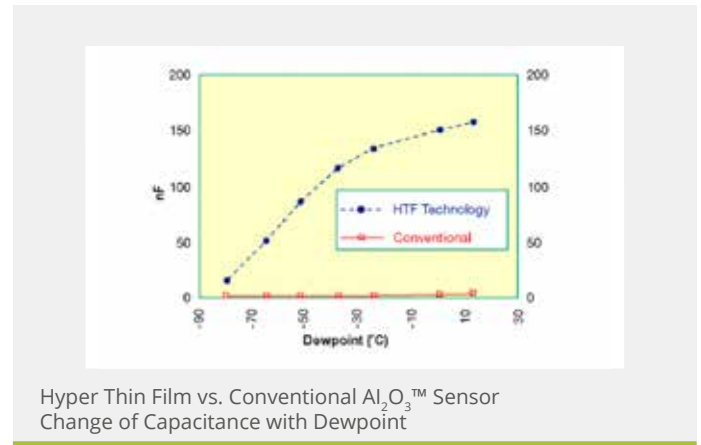

Temperature Coefficient

HTF aluminum oxide sensors are completely temperature stable over almost their full range. Only below -70°C (dp) does the measurement become slightly temperature sensitive. Temperature coefficients remain small enough though, to allow for software compensation.

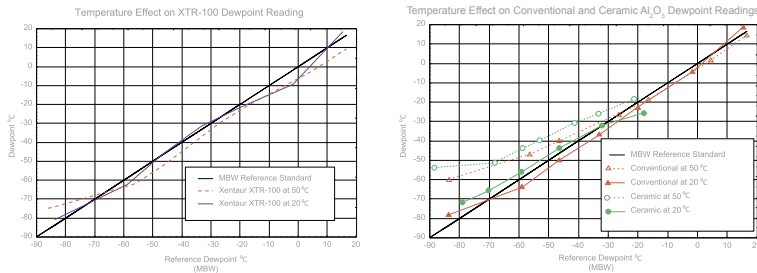

The temperature coefficients of conventional and ceramic sensors relative to their sensitivity are too large to allow for an accurate compensation through software.

Drift

HTF sensors do not suffer from drift like conventional sensors. Their response curve remains virtually the same even after six month of operation at an elevated temperature.

TECHNICAL SPECIFICATIONS

System Highlights:

Type	Hyper-Thin-Film high capacitance Al ₂ O ₃ ™ Dewpoint Range XTR-100™ -100°C to +20°C (-148°F to +68°F) XTR-65™ -65°C to +20°C (-85°F to +68°F)
Capacitance	15nF to 200nF
Accuracy	±2°C (± 3.6°F) for -100°C to 0°C Dewpoint ±3°C (± 5.5°F) for 0°C to +20°C Dewpoint
Repeatability	±0.5°C (±0.9°F)
Temperature Range	-10°C to +70°C (+14°F to +158°F)
Sample Flow Range (linear vel. @ 1 atm.)	Static to 100 m/s
Storage Temperature	-40°C to +80°C (-40°F to +176°F)
Calibration Method	Field span check, NIST/NPL traceable, multipoint calibration

Electronics:

Input resolution	0.1°C (dp)
Indicators	3.5 digit LCD with custom legends
Engineering units	°C, °F, ppmv, LBS H ₂ O/mm scf, gm H ₂ O/M ³
Controls	3 push buttons, all settings stored in EPROM
Output	Analog 4-20mA
Alarms	The 4-20mA of the digital output may be used by an external device to operate relays
Isolation	Sensor and case are isolated from the current loop and shunted with 33V transorbs

Mechanical:

Enclosure	Stainless steel (Weather proof cover optionally available)
Pressure operating range	340 bar (5,000 PSI)
Electrical connections	2.1 mm power jack with retainer thread size 3/4"-16, 14mm x 12.5mm
Cable	Two conductor cable
Power Requirements	10 to 33 VDC, the instrument draws 4-20mA depending on measurement dewpoint
Warranty	One year



GAIN REAL-TIME INSIGHT INTO YOUR PROCESS

Process Insights manufactures and delivers premium sensors, monitors, detectors, analyzers, instrumentation, and software that are mission-critical to keep your operations, personnel, and the environment safe – every day across the globe.

Get the most reliable, precision analytical technologies available on the market today. We will work to match your needs and budget, and provide the optimal, and most stable process analysis solution for your application.

CENTERS OF EXCELLENCE | PROVIDING PROVEN SOLUTIONS

Process Insights is committed to solving our customers' most complex analytical, process, and measurement challenges everyday.

Process Insights – The Americas

4140 World Houston Parkway Suite 180, Houston, TX 77032, USA +1 713 947 9591

Process Insights – EMEA

ATRICOM, Lyoner Strasse 15, 60528 Frankfurt, Germany +49 69 20436910

Process Insights – APAC

Wujiang Economic and Technology, Development Zone, No. 258 Yi He Road, 215200 Suzhou, Jiangsu Province, China +86 400 086 0106

For a complete range of products, applications, systems, and service options, please contact us at: info@process-insights.com

For a complete list of sales & manufacturing sites, please visit: <https://www.process-insights.com/about-us/locations/>

COSA Xentaur, Tiger Optics, Extrel, Alpha Omega Instruments, ATOM Instrument, MBW Calibration, MGA, Guided Wave, ANALECT and LAR TOC Leader are trademarks of Process Insights, Inc.



REVOLUTIONIZING MEASUREMENT

EVERYWHERE