

PRODUCT DATASHEET

MAX300-LG™

Laboratory Gas Analyzer



Fast Response

Process Control

**Stable
Measurement**

- Real-Time Gas Analysis
- Catalysis Monitoring
- Trace Gas Detection
- Environmental Research
- Multipoint Process Control

SPECIFICATIONS

System Highlights:	
Detectable compounds	Any gas or vapor sample
Detection range	– Faraday detector: 100% – 5 ppm – Electron multiplier: 100% – 5 ppb* – Membrane inlet: 100% – 10 ppt*
Analysis rate	0.005 – 16 seconds per component – User selectable
Number of components	Unlimited
Number of analysis routines	Unlimited
Number of user configurable data tags	Unlimited
Precision	<0.05% RSD over 24 hours**
Stability	<0.5% RSD over 30 days**
Ionization energy control for reduced fragmentation	
Automated detector switching within a single scan	
Filaments	Two, one active and one spare with automatic switchover
Analyzer maintenance	1-3 years [†]
Roughing pump	6-12 months [†]
Manual or fully automated calibration and validation	3-12 month calibration intervals
Mass range options	1-250, 300, 500 amu
19 mm High-transmission quadrupole filter	

* Matrix dependent. Documented on trace air components and benzene.

** Based on the analysis of 1% argon, scan speed 1 second per analysis with no recalibration or intervention of any kind.

[†] Application dependent.

MAX300-LG System Specifications

Power Supply Options:

- 110 vAC +/- 10% vAC 50/60 hz, 10 Amp Circuit
- 230 vAC +/- 10% vAC 50/60 hz, 10 Amp Circuit

Power Consumption:

- Nominal 700 Watts

Weight:

- Approximately 165 lbs (75 kg)
- Optional cart: 40 lbs (18 kg)

Ambient Requirements:

- 55°F to 80°F (13°C to 27°C)
- Area Classification: General Purpose

Relative Humidity:

- 0-90% non-condensing

Data System and Communications:

- System control interface options: Ethernet or USB
- Login security levels: Administrator, User, Viewer
- External communications: Ethernet, Modbus serial, digital I/O, analog I/O, OPC

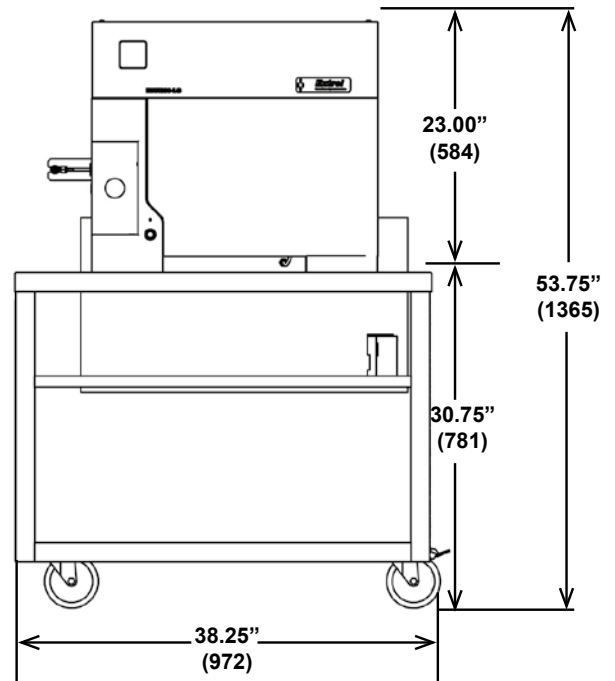

MAX300-LG enclosure with cart

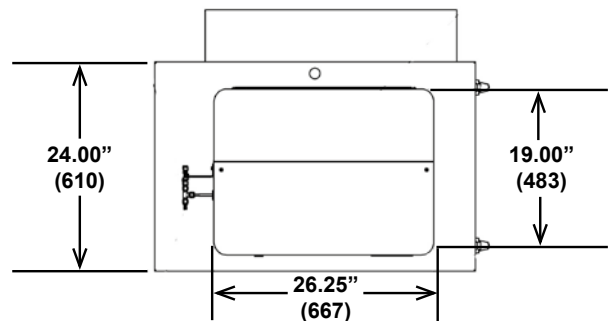

MAX300-LG enclosure with cart top view.

Dimensions shown in inches [cm]

Exceptional Worldwide Service and Support

For over 55 years, we have been committed to providing the highest quality support services for thousands of instruments installed worldwide. Factory trained and certified personnel offer industry-leading support to our customers at every stage of their analytical process.

GAIN REAL-TIME INSIGHT INTO YOUR PROCESS

Process Insights delivers premium analytical sensors, analyzers, instrumentation, software and solutions that are mission-critical to keep your operations, personnel, and the environment safe. Our commitment to customer satisfaction is evident through our diverse range of products, programs, and services, designed to accommodate various budgets and application needs.

CENTERS OF EXCELLENCE | PROVIDING PROVEN SOLUTIONS

Process Insights – The Americas

14400 Hollister Street, Suite 800B, Houston, TX 77066, USA +1 713 947 9591

Process Insights – EMEA

ATRICOM, Lyoner Strasse 15, 60528 Frankfurt, Germany +49 69 20436910

Process Insights – APAC

Wujiang Economic and Technology, Development Zone, No. 258 Yi He Road, 215200 Suzhou, Jiangsu Province, China +86 400 086 0106

For a complete range of products, applications, systems, and service options, please contact us at: info@process-insights.com

For a complete list of sales & manufacturing sites, please visit: <https://www.process-insights.com/about-us/locations/>

