

PRODUCT BROCHURE

MAX300-RTG™ 2.0

Real-time Gas Analyzer with Touch Screen Interface

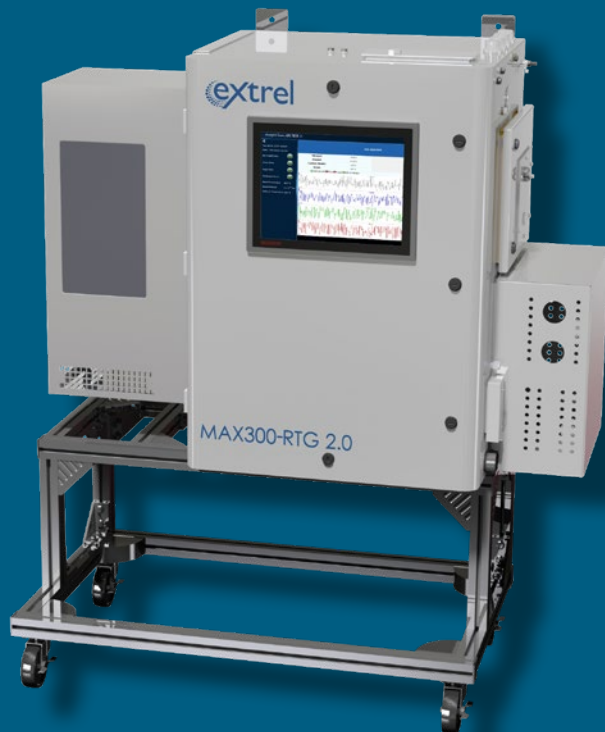

**Continuous,
real-time analysis**

**Full, speciated
composition**

**High sensitivity
and wide
dynamic range**

- Fast analysis for advanced process control, environmental compliance, and life safety monitoring
- Complete quantitative stream composition: total application coverage with fewer analyzers required
- Multi-port stream selector for up to 160+ samples
- Low maintenance and easy to operate with simple touch screen interface
- Industry-best customer support and application team

Reliable Data, Optimized Performance

With over four decades of excellence in industrial automation and thousands of installations worldwide, our process mass spectrometers provide the rugged stability and ease-of-use necessary for continuous operation in demanding manufacturing environments.



Hydrocarbon Processing

- Flare Gas Analysis
- Ethylene Cracker Control
- Polyethylene
- Fuel Gas BTU
- Ethylene Oxide
- LNG
- PVC and EDC
- Benzene



Syngas Manufacturing

- Ammonia
- Methanol
- Hydrogen
- Gasification
- Acetic Acid
- Low-Sulfur Diesel



Metals Manufacturing

- Steel Carbon Content
- Blast Furnace Off Gas
- Coke Making
- EAF Monitoring



Gas Purity

- Trace Contamination
- Pharmaceutical Solvents
- Semiconductor Manufacturing
- Scrubber Efficiency
- Food and Beverage Gas

Introducing the MAX300-RTG 2.0

Optimize Your Manufacturing

Mass spectrometry is a powerful tool for process control, automation, and environmental analysis. Rapid, accurate gas analysis enables high-precision process control, increased efficiency for production and environmental compliance.

The MAX300-RTG 2.0 uses cutting-edge quadrupole mass spectrometry technology to deliver continuous, online gas monitoring for industrial process control and environmental compliance.

Easily Measure Multiple Process Points or Production Lines With One Analyzer

It has the speed necessary to analyze the total composition of a sample in seconds, and can be fully automated to measure several points in a process, or multiple production lines, with a single analyzer.

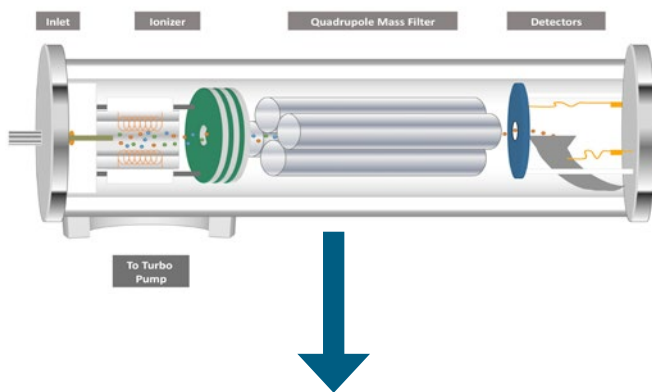

The mass spectrometer uses an ionizer to break sample molecules into charged fragment ions that are then separated based on their mass-to-charge ratio as they move through the electric fields generated by the quadrupole mass filter. The ions register a current at the detector, creating a set of peaks called a mass filter.

Our industry-leading 19mm quadrupole mass filter, combined with state of the art electronics, delivers real optimized performance and more:

- Near-zero mass scale drift for outstanding measurement precision and stability
- Uniform resolution across the entire mass range for ultra-high sensitivity to all compounds
- Extreme resistance to corrosion and contamination
- Performance specifications superior to other mass spectrometers and commercial process technologies

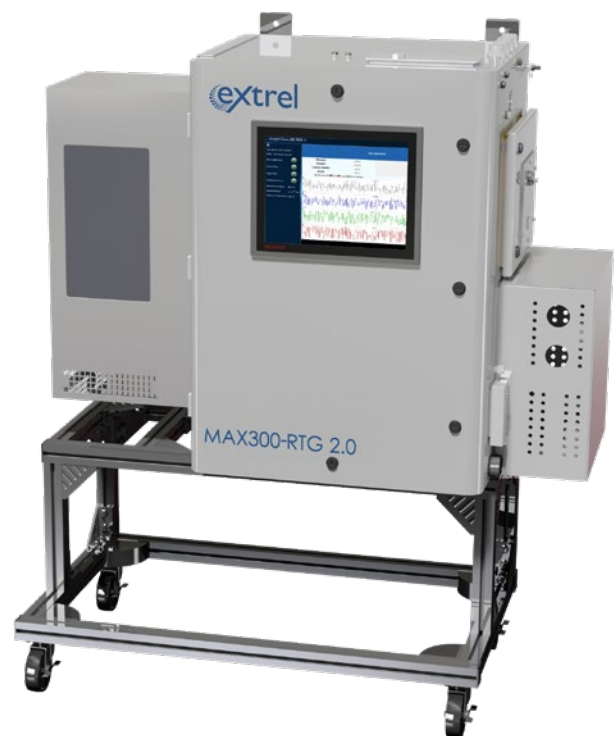

MAX300-RTG 2.0
Industrial Gas Analyzer with GUI

The ions register a current at the detector, creating a set of peaks called a mass spectrum. Each compound has a unique spectrum, making mass spectrometry a highly selective, flexible technique.

Rapid Online Analysis to Maximize Your Production

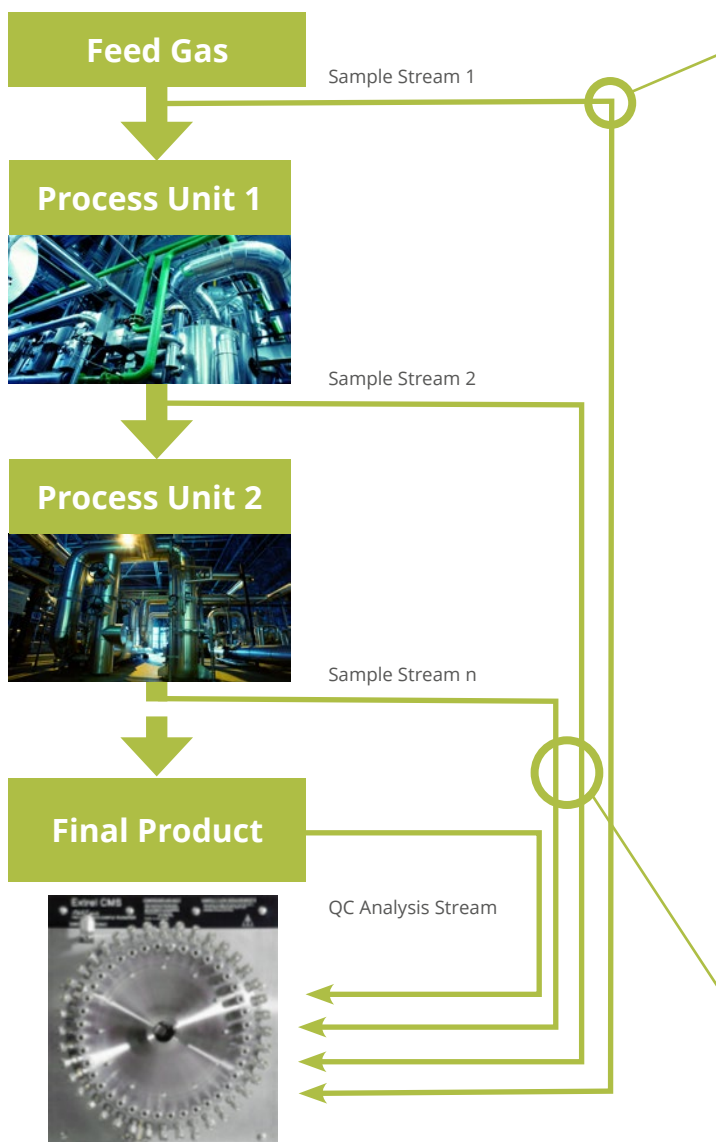

The 80 Port FASTvalve Sample Selector
The inlet system of the MAX300-RTG 2.0 can be configured with any number of zero-dead-volume sample selector options.

Consistent Ongoing ROI

- Fast online gas analysis for increased manufacturing efficiency, product yield, and equipment uptime
- Full stream composition provides additional information necessary for advanced process control
- Lower capital cost compared to other technologies
- Reduced operation costs due to low maintenance and utility requirements
- By monitoring the operation of several process units, the MAX300-RTG 2.0 is often used to replace multiple gas chromatograph (GC) systems

Accuracy and Flexibility

Component	% Molecular Concentration	Precision % Absolute
Hydrogen	16.5	0.006
Methane	77.9	0.007
Nitrogen	0.38	0.002
Propane	0.9	0.001
Ethane	2.35	0.002
N-pentane	0.16	0.001
Isobutane	0.27	0.001
Carbon dioxide	0.95	0.001
Isopentane	0.15	0.001
N-Butane	0.45	0.001
Hexane	0.01	0.0002
Hydrogen sulfide	0.001	0.00001

Example 1. Process Feed Gas

The MAX300-RTG 2.0 measures all of the hydrocarbons in the feed gas stream as well as ppm contaminants, like H₂S. Control parameters, such as BTU value, Specific Gravity, and Wobbe Index, are instantly calculated and transmitted for use by the plant's process control system.

Precision and Control

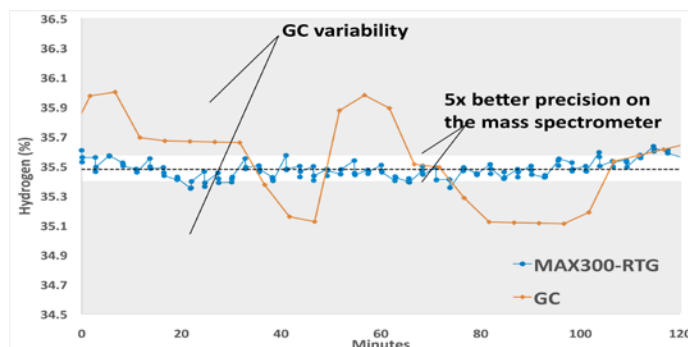

Example 2. Polyethylene Reactor Control

Fast, high-precision data allows the plant to operate process units closer to optimum conditions. This data was collected running a mass spectrometer side-by-side with a GC at a polyethylene plant.

Superior Process Control with Process Insights

	GC	MAX300-RTG 2.0
Cycle time	5 min	29 sec
Measurements	3 components	10 components
# of samples monitored	1 reactor only	4 reactors

System Specifications

Detectable compounds:

Any gas or vapor sample

Integrated touch screen:

15" display
Customizable and interactive
Full Access to Questor5 software

Detection range:

Faraday detector: 100% – 5 ppm
Electron multiplier: 100% – 5 ppb*
Membrane inlet: 100% – 10 ppt*

Number of sample streams:

16, 31, 40, 80, 120, 160+

Analysis rate:

0.1 – 16 seconds per component
Customizable

Number of components: Unlimited

Number of analysis routines: Unlimited

Number of user configurable data tags:

Unlimited

Precision: <0.05% RSD over 24 hours**

Stability: <0.5% RSD over 30 days**

Filaments: Two, one active and one spare with automatic switchover

Analyzer maintenance: 1-3 years[†]

Roughing pump: 6-12 months[†]

Manual or fully automated calibration and validation: 3-12 month calibration intervals

Mass range options: 1 to 250, 300, or 500 amu

Mass filter: 19mm quadrupole for high precision, sensitivity and stability

* Matrix dependent. Documented on trace air components and benzene.

** Based on the analysis of 1% argon, scan speed 1 second per analysis.

[†] Application dependent.

Low Maintenance, Easy to Use

The MAX300-RTG 2.0 is a 24-7 online gas analyzer with documents uptime of >99%. This uptime is achieved through a combination of low maintenance requirements and ease of use. This analyzer features a modular design, including pre-assembled service replacement parts to avoid lengthy maintenance requirements. Examples include our plug-and-play ionizer, which reduces the cleaning requirement of older styles and features a built-in spare filament to reduce emergency maintenance, and the VacTrac, allowing for easy access to the pumps and vacuum chamber.

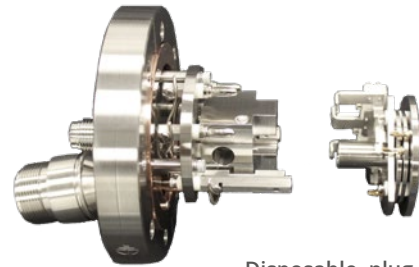

Disposable, plug-and play ionizer for MAX300 series

The Questor5 control software that drives the MAX300-RTG 2.0 measures all sample points in a fully customizable sequence for site-specific, automated production control. The intuitive web-based interface allows the user to check instrument status, review data, or run a validation sequence locally from the new, integrated touchscreen or remotely, anywhere on the plant network, while maintaining government and industry security standards for login and electronic record keeping (21 CFR 11).



Simultaneously view current results and calculations, trends, and current analyzer status parameters with the easy-to-use Questor5 software and graphical user interface.

MAX300-RTG System Specifications

Power Supply Options:

- 115 VAC (+/- 10%), 50/60 Hz, Two 20 Amp Circuits
- 230 VAC (+/- 10%), 50/60 Hz, One 20 Amp Circuit

Power Consumption:

- Nominal 2740 Watts
- Heat Load: 2991 Watts (10,200 BTU/hour)

Weight:

- Standard Enclosure: 450 lbs (205 kg)*
- Optional cart: 40 lbs (18 kg)

Ambient Requirements:

- Temperature: -4°F to 120°F (-20°C to 49°C)
- With A/C, cold start $\geq 54^{\circ}\text{F}$ (12°C)

Area Classification Options:

- General Purpose
- Class 1, Division 2, Groups A,B,C,D, T4 or T3
- IEC/ATEX, Zone 2, Group IIC or IIB +H2*, T3 or T4

Additional Utilities:

- Purge gas (for hazardous area installations)
- Calibration gas cylinders: minimum 2*

Data System and Communications:

- External Control Interface: Modbus (TCP/IP, Fiber Optics, Serial) or Analog Input
- Login security levels: Administrator, User, Viewer
- External Communications: Modbus (TCP/IP or Serial), Analog and Digital I/Os, Fiber Optics

*Configuration dependent

Exceptional Worldwide Service and Support

For over 50 years, we have been committed to providing the highest quality support services for the thousands of instruments installed worldwide. Factory trained and certified personnel offer industry-leading support to our customers at every stage of process development and manufacturing.

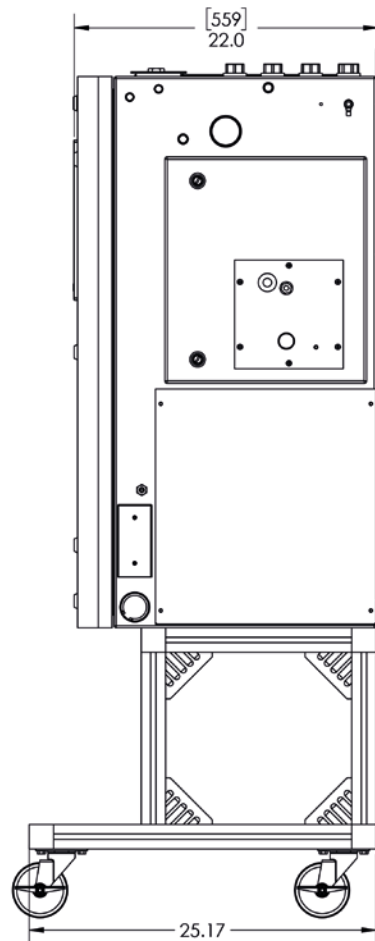
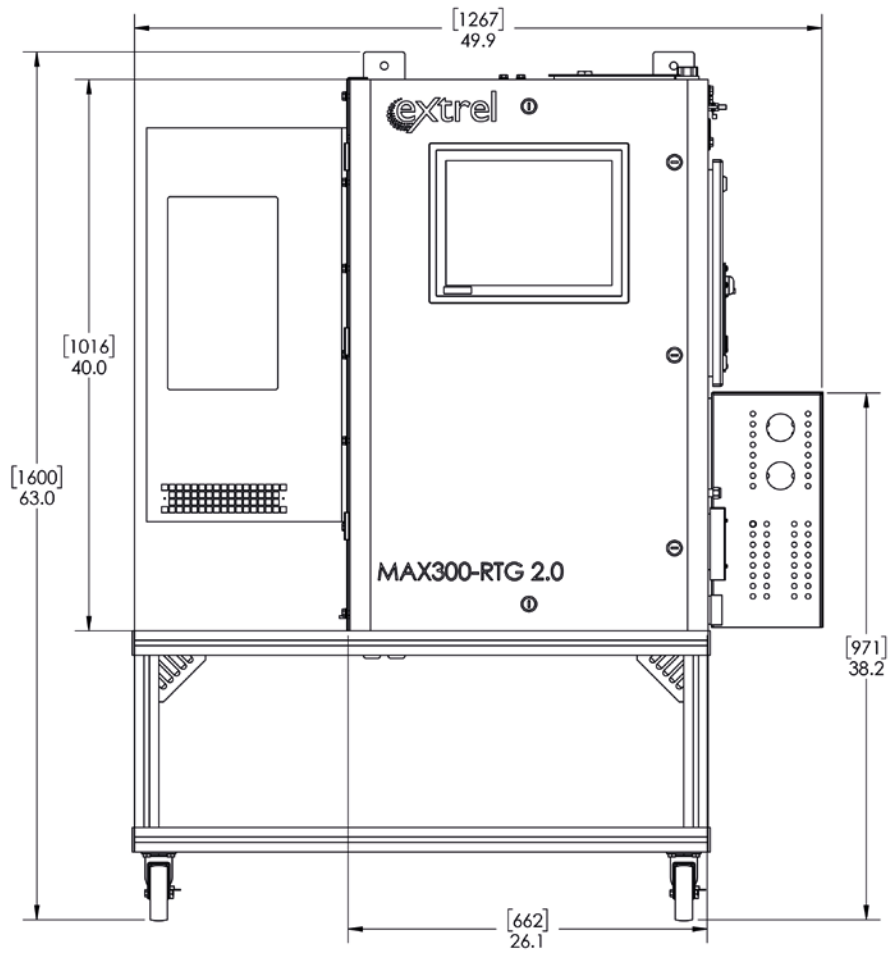

MAX300-RTG 2.0 enclosure with Cart.
Dimensions shown in inches [mm]

GAIN REAL-TIME INSIGHT INTO YOUR PROCESS

Process Insights delivers premium analytical sensors, analyzers, instrumentation, software and solutions that are mission-critical to keep your operations, personnel, and the environment safe. Our commitment to customer satisfaction is evident through our diverse range of products, programs, and services, designed to accommodate various budgets and application needs.

CENTERS OF EXCELLENCE | PROVIDING PROVEN SOLUTIONS

Process Insights – The Americas

14400 Hollister Street, Suite 800B, Houston, TX 77066, USA +1 713 947 9591

Process Insights – EMEA

ATRICOM, Lyoner Strasse 15, 60528 Frankfurt, Germany +49 69 20436910

Process Insights – APAC

Wujiang Economic and Technology, Development Zone, No. 258 Yi He Road, 215200 Suzhou, Jiangsu Province, China +86 400 086 0106

For a complete range of products, applications, systems, and service options, please contact us at: info@process-insights.com

For a complete list of sales & manufacturing sites, please visit: <https://www.process-insights.com/about-us/locations/>

