

PRODUCT DATASHEET

MAX300-BIO™

Bioreactor Fermentation Mass Spectrometer



Fast Response

Process Control

Stable Measurement

- Quantitative analysis of individual contaminants
- PPT detection limits
- Analysis time in seconds
- Multiport sample systems for total site monitoring
- Precision & accuracy for safety and regulatory reporting
- Minimal maintenance required

MAX300-BIO System Specifications

Power Supply Options:

- 120 VAC, 50/60 Hz, Two 15 Amp circuits
- 230 VAC, 50/60 Hz, One 20 Amp circuit

Power Consumption:

- Nominal 2500 Watts
- Startup 2750 Watts
- Heat Load: 2500 Watts (8500 BTU/Hr)

Weight:

- Standard Enclosure: 420 lbs (190 kg)
- ATEX Enclosure: 560 lbs (254 kg)
- Optional cart: 40 lbs (18 kg)

Ambient Requirements:

- Temperature: -4°F to 120°F (-20°C to 49°C)
- With A/C, cold start $\geq 54^\circ\text{F}$ (12°C)
- Area Classification Options:
 - General Purpose
 - Class 1, Division 2 Groups B, C, D, T3
 - Class 1, Division 1 Groups B, C, D, T3
 - ATEX Zone 1 or Zone 2, Group II B +H2, T4

Additional Utilities:

- Purge gas (for hazardous area installations)
- Base calibration requirement: 2 gas bottles

Data System and Communications:

- System control interface options: Ethernet, RS-422 4-wire
- Login security levels: Administrator, User, Viewer
- External communications:
 - Ethernet, Modbus serial, digital I/O, analog I/O, OPC

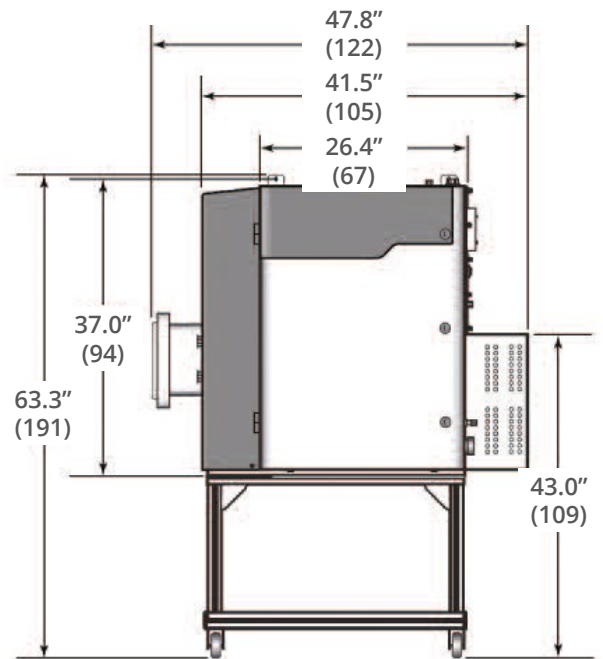

MAX300-BIO standard enclosure dimensions with A/C and Cart

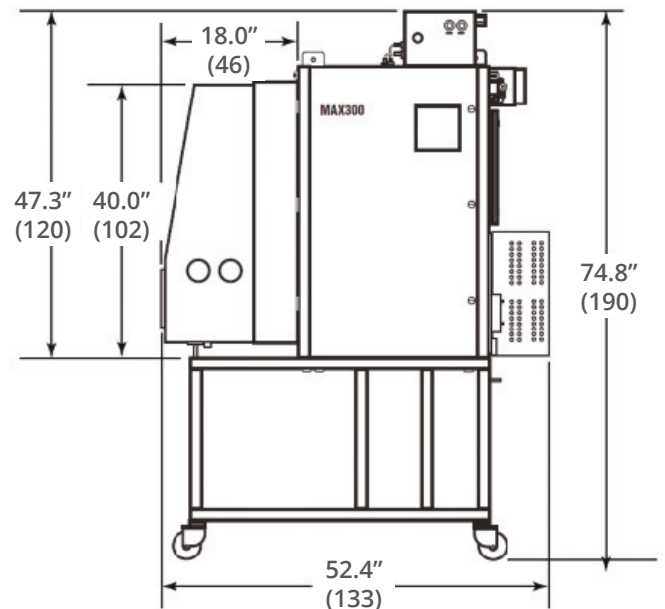

MAX300-BIO ATEX enclosure dimensions with A/C and Cart

Dimensions shown in inches [cm]

Exceptional Worldwide Service and Support

For over 50 years, we have been committed to providing the highest quality support services for the thousands of instruments installed worldwide. Factory trained and certified personnel offer industry-leading support to our customers at every stage of the environmental monitoring application.

SPECIFICATIONS

System Highlights:	
Detectable compounds	Any gas or vapor sample
Detection range	100% - 10 ppb standard, 10 ppb with the electron multiplier option*
Number of sample streams	16, 31, 40, 80+
Analysis rate	<0.4 seconds per component
Number of components	Unlimited
Number of analysis routines	Unlimited
Number of user configurable data tags	Unlimited
Analysis precision	<0.25% relative standard deviation**
Stability	<0.5% relative standard deviation over 30 days**
Dual filaments	One active and one spare with automatic switchover
Maintenance	Typically two PMs per year
Manual or fully-automated calibration and validation	
Mass range option	1-200, 300, or 500 amu
19 mm high-transmission quadrupole filter	

* Documented on trace benzene in air.

** Based on the analysis of 1% argon.

GAIN REAL-TIME INSIGHT INTO YOUR PROCESS

Process Insights delivers premium analytical sensors, analyzers, instrumentation, software and solutions that are mission-critical to keep your operations, personnel, and the environment safe. Our commitment to customer satisfaction is evident through our diverse range of products, programs, and services, designed to accommodate various budgets and application needs.

CENTERS OF EXCELLENCE | PROVIDING PROVEN SOLUTIONS

Process Insights – The Americas

14400 Hollister Street, Suite 800B, Houston, TX 77066, USA +1 713 947 9591
info.americas@process-insights.com

Process Insights – EMEAI

ATRICOM, Lyoner Strasse 15, 60528 Frankfurt, Germany +49 69 20436910
info.emeai@process-insights.com

Process Insights – APAC & CN

Wujiang Economic and Technology, Development Zone, No. 258 Yi He Road, 215200 Suzhou, Jiangsu Province, China +86 400 086 0106
info.apac@process-insights.com
info.cn@process-insights.com

For a complete list of sales & manufacturing sites, please visit:
<https://www.process-insights.com/about-us/locations/>

